

A76

SERVICE MANUAL

AKAI SURROUND STEREO
TAPE DECK

MODEL **280D-SS**

A76



TABLE OF CONTENTS

I.	SPECIFICATIONS	2
II.	MEASURING METHOD	4
III.	DISMANTLING OF TAPE TRANSPORT UNIT & AMPLIFIERS	6
IV.	TRANSPORT MECHANISM	8
V.	MECHANISM ADJUSTMENT	17
VI.	AMPLIFIER ADJUSTMENT	22
VII.	TROUBLE SHOOTING CHART	25
VIII.	COMPOSITE VIEWS OF COMPONENTS	28
IX.	SCHEMATIC DIAGRAM	

WHEN PLACING ORDER FOR PARTS,
PLEASE USE SEPARATE PARTS LIST.

1. SPECIFICATIONS

STYLE	: Portable	INPUT	
WEIGHT	: 21.5 Kg (47.3 lbs)	LINE INPUT	: Above 0.1 V (Impedance 150 K Ω)
DIMENSIONS	: 435(W) x 505(H) x 250(D) mm (17.4" x 20.2" x 10")	MIC INPUT	: Above 0.5 mV (Impedance 10 K Ω)
POWER SUPPLY	: 100 V to 240 V AC 50/60 Hz	DIN INPUT	: High . . . Above 60 mV (Impedance 70 K Ω)
POWER CONSUMPTION	: 40 to 140 W		Low . . . Above 10 mV (Impedance 70 K Ω)
PLAYBACK AND RECORDING SYSTEM	: 4-track 4-channel/2-channel compatible Stereo recording and playback	FAST-FORWARD & REWIND TIME	: 83 seconds for a full 1,200 ft. tape at 50 Hz 68 seconds for a full 1,200 ft. tape at 60 Hz
TAPE SPEED	: 7-1/2 and 3-3/4 ips	MONITOR SYSTEM	: Program being recorded can be monitored through stereo headphones. External speakers or external main amplifier.
TAPE SPEED DEVIATION	: Within $\begin{matrix} +1.0\% \\ -0.5\% \end{matrix}$ at 7-1/2 ips (FWD/REV) Within $\pm 1.0\%$ at 3-3/4 ips (FWD/REV)	MOTOR	
WOW AND FLUTTER (PLAYBACK ONLY)	: Less than 0.12% R.M.S. at 7-1/2 ips Less than 0.18% R.M.S. at 3-3/4 ips	CAPSTAN MOTOR	: Servo control 2-speed motor condenser capacity 3.5 μ F (50 Hz) 3.0 μ F (60 Hz) Revolutions : 7-1/2 ips 520 r.p.m 3-3/4 ips 260 r.p.m
FREQUENCY RESPONSE	: 30 to 22,000 Hz ± 3 dB at 7-1/2 ips 30 to 13,000 Hz ± 3 dB at 3-3/4 ips	REEL MOTOR	: Two 6-pole eddy current outer-rotor motors Condenser capacity 4.0 μ F (50 Hz) 3.0 μ F (60 Hz) Revolutions : 930 r.p.m at 50 Hz 100 V 1120 r.p.m at 60 Hz 110 V
EQUALIZATION	: Correct equalization for playback of tapes recorded to the NAB curve	BIAS FREQUENCY	: 100 to 110 KHz
SIGNAL TO NOISE RATIO	: Better than 48 dB at 7-1/2 ips (FWD/REV) Better than 46 dB at 3-3/4 ips (FWD/REV)	HEADS	
DISTORTION (TOTAL HARMONICS)	: Less than 2% at 1,000 Hz 0 VU recording (7-1/2 ips) Less than 3% at 1,000 Hz 0 VU recording (3-3/4 ips)	RECORDING HEAD	: In-line 4-track 4-channel/2-channel stereo Impedance 125 $\Omega \pm 20\%$ at 1,000 Hz Gap 4/1000 mm
CROSS-TALK	: Better than 45 dB (2 CH) Better than 40 dB (4 CH)	PLAYBACK HEAD	: In-line 4-track 4-channel/2-channel stereo Impedance 1,200 $\Omega \pm 15\%$ at 1,000 Hz Gap 2/1000 mm
ERASE RATIO	: Better than 70 dB	ERASE HEAD (A)	: In-line 4-track 2-channel stereo Impedance 195 $\Omega \pm 10\%$ 110 KHz
INSULATION RESISTANCE	: More than 50 M Ω	ERASE HEAD (B)	: In-line Full track Impedance 350 $\Omega \pm 10\%$ at 110 KHz
INSULATION DURABILITY	: 1,000 V AC for more than one minute duration	RECORDING LEVEL INDICATOR	: Two Vertical twin type VU meters
OUTPUT			
LINE OUTPUT	: 4-channel +4 dB (1,228 V) ± 1.5 dB at 0 VU indication, 250 Hz 0 VU recorded tape. 2-channel +4 dB ± 1 dB (FWD) ± 1.5 dB (REV) at 0 VU indication when using a 250 Hz recorded tape. Required load impedance more than 25 K Ω		
DIN OUTPUT	: 0.4 V (Impedance 10 K Ω)		
HEAD PHONE OUTPUT	: 30 to 40 mV / 8 Ω		

TRANSISTORS USED

:	2SC458LG (C)	20
	2SC945 (Q) (R)	18
	2SC711 (E) (D) or 2SC536 (E) (F) ..	12
	2SC968 (2) (3)	4
	2SC911 (2) (3)	2
	2SC968 (3)	2
	2SA564 (R)	2
	2SD234 (Y)	2
	2SC968	1
	2SC711 (G) (F) or 2SC536 (G) (H) ..	1
	2SC945 (R) (S)	1
	2SC1013	1
	2SC968 (3) (4)	1

I C USED : LD-3141

DIODES USED :	IN34A	32
	10D1	15
	10D4	2
	RD9A	1
	10DC-1 (RED)	1
	10DC-1 (BLK)	1

REEL CAPACITY : 7", 5" reels can be used.

RECORDING CAPACITY

- : 2-channel stereo 2-hours (1,200 ft,
tape 3-3/4 ips)
- 4-channel stereo 1-hours (1,200 ft,
tape 3-3/4 ips)

II. MEASURING METHOD

TAPE SPEED DEVIATION

1. Method involving use of pre-recorded tape
Playback a tape pre-recorded at 1,000 Hz ($\pm 0.1\%$) on the recorder to be tested. Connect the appropriate output to a frequency counter meter in order to measure the tape speed deviation.
2. Method involving use of timing tape (designed for tape speed measurement)

This method utilizes a timing tape marked at intervals of 7-1/2". The running time of over 60 marked sections of the tape is measured in order to calculate the tape speed deviation. In applying this method, however, it should be kept in mind that timing tape stretch or contract measurement is inevitable, so that it is necessary to measure the total length of the tape in advance.

WOW AND FLUTTER

Playback a 3,000 Hz pre-recorded tape of which the wow and flutter level is guaranteed to be smaller than 0.07% for measurement by means of a wow meter. It is also possible for a 3,000 Hz sine wave to be recorded and played back for measurement by means of a wow meter. In this case, however, the wow meter indicates a value as much as twice the value given in the specifications.

FREQUENCY RESPONSE

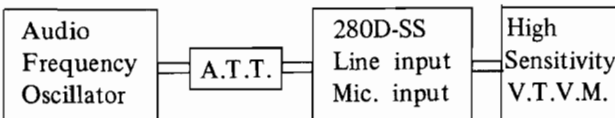

Connect the measuring instruments as shown in the above diagram, and measure the frequency response in the following sequence.

RECORD :

- 1) Supply a 1,000 Hz sinewave to the Line Input of the recorder to be tested through an attenuator from an audio frequency oscillator.
- 2) Set the Monitor Switch to "SOURCE" position and adjust the line input volume so that the VU Meter needle indicates "0" VU.
- 3) Set the TAPE SPEED SELECTOR to 7-1/2" or 3-3/4" position.
- 4) Under the condition described in (2), lower the input level 20 dB by means of the attenuator.
- 5) Record the spot frequency in the range of 30 Hz to 20,000 Hz from the audio frequency oscillator.

PLAYBACK :

- 6) Set the Monitor Switch to "TAPE" position.
- 7) Connect a High Sensitivity V.T.V.M. to the Line Output Jack. (VTVM with millivolt scale.)
- 8) Playback the recorded tape.

- 9) Playback the recorded spot frequencies and make a memo of output level and plot the value on a graph. With 1,000 Hz frequency as standard (0 dB), read other frequency indications.

Note : Frequency response shown in specifications represent values when using AKAI "100F" (FUJI S-100) Tape.

TOTAL HARMONIC DISTORTION FACTOR

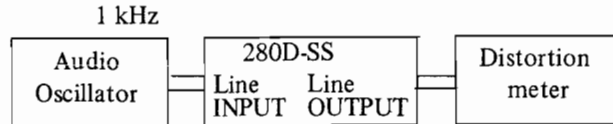

Connect the measuring instrument as shown above, and record a 1,000 Hz sine wave at "0" VU. Playback the resulting signal and measure the overall distortion factor. Measure the noise level of the tape recorder with the tape removed ; connect the audio oscillator directly to the distortion meter for measurement of the distortion factor of the oscillator.

The required distortion factor can be obtained from the results of the above measurement by using the following formula :

$$d_0 = d - d_1 - d_2$$

Where, d_0 = Required

d = Overall distortion factor

d_1 = Noise level

d_2 = Distortion factor of the oscillator

Note : New tape of particularly good quality should be used for measurement of the distortion factor. AKAI "100L" (FUJI S-100) is recommended.

SIGNAL TO NOISE RATIO

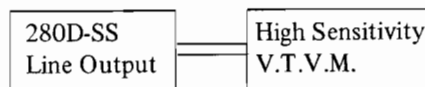

Set the Tape Speed Selector to "7-1/2 ips" position and playback a tape containing a 250 Hz sine wave recorded at "0" VU level on a standard recorder. Connect a High sensitivity V.T.V.M. to the line output jack of the recorder and measure its output. Then remove the tape and measure the noise level under the same condition. Convert into decibels each of the measured values.

CROSS TALK

1. Between the tracks (2-Channel)

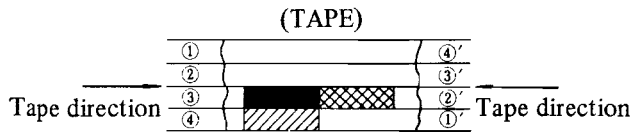

As shown in the figure, first record a 1,000 Hz sine wave on track No. 3 at +3 VU level. Next, remove the 1,000 Hz input signal and record under a non-input condition. Then, playback the tape on tracks 3 and 1 (reversed condition of tape) through the 1,000 Hz B.P.F. (Band Pass Filter, Sensitivity . . . 1 : 1) and obtain the ratio between the two by using the following formula.

$$C = 20 \log \frac{E_0}{E_2 - E_1} \text{ (dB)}$$

C = Desired cross talk ratio (dB)

E_0 = 1,000 Hz signal output level

E_2 = 1,000 Hz cross talk output level

E_1 = Non-input signal record level



2. Between the channels (4-Channel)

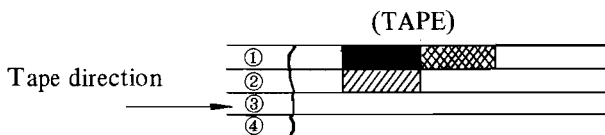

As shown in the figure, first record a 1,000 Hz sine wave on track No. 1 at +3 VU level. Next, remove the 1,000 Hz input signal and record under a non-input condition.

Then, playback the tape on track No. 1 and No. 2 through the 1,000 Hz B.P.F. (Band Pass Filter, Sensitivity . . . 1 : 1) and obtain a ratio between the two from the following formula.

$$C = 20 \log \frac{E_0}{E_2 - E_1} \text{ (dB)}$$

C = Desired cross-talk ratio (dB)

E_0 = 1,000 Hz signal output level

E_2 = 1,000 Hz cross-talk output level

E_1 = Non-input signal record level



III. DISMANTLING OF TAPE TRANSPORT UNIT & AMPLIFIER

In case of trouble, etc. necessitating disassembly, please disassemble in the order shown in photographs. Re-assemble in reverse order.

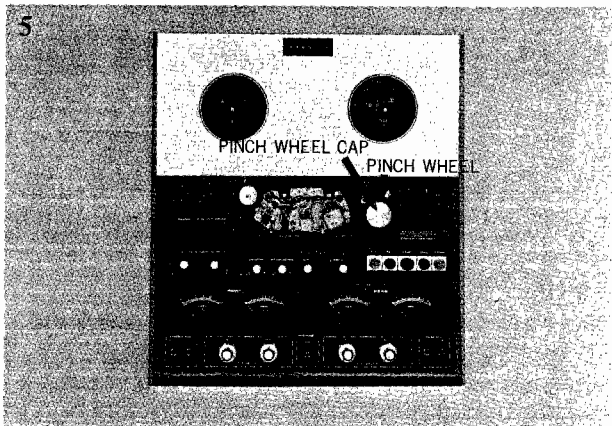
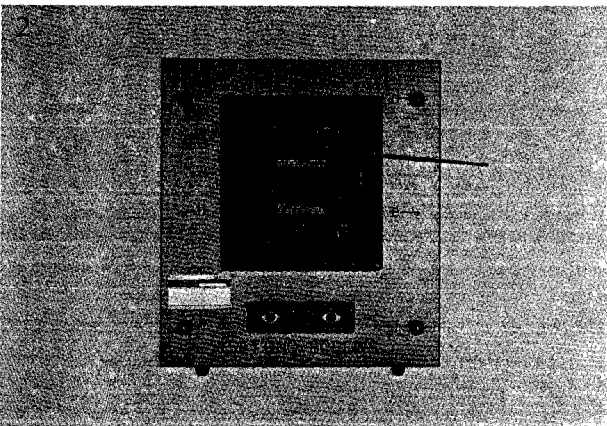
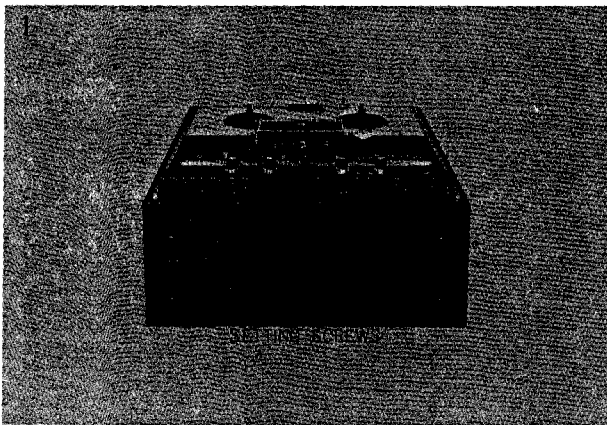

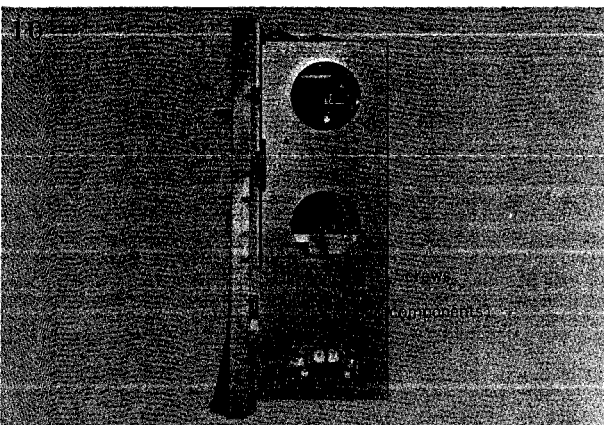
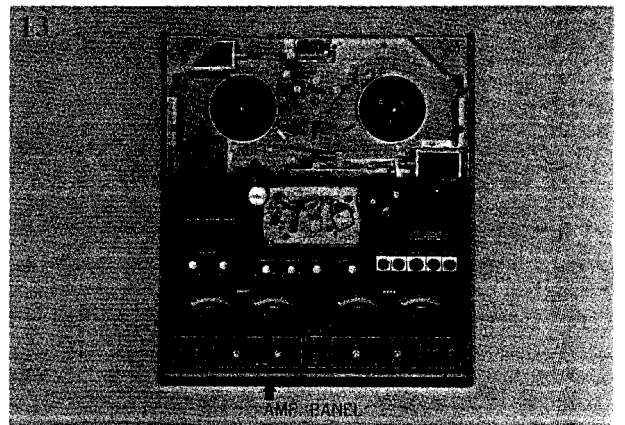
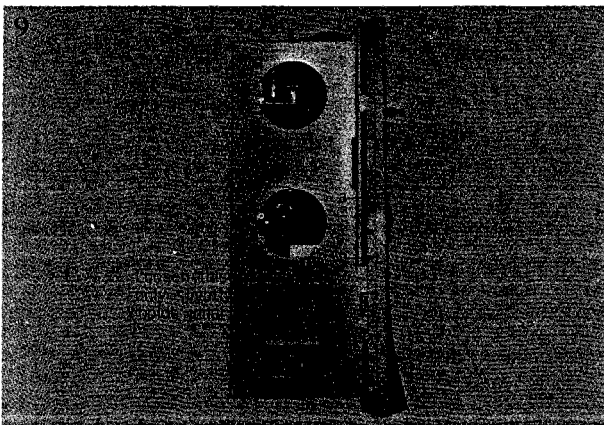
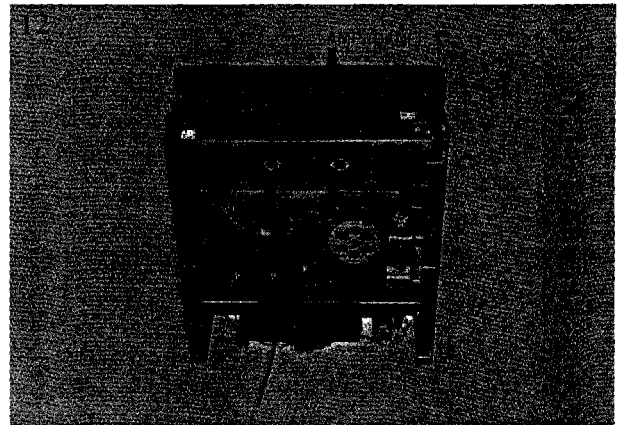
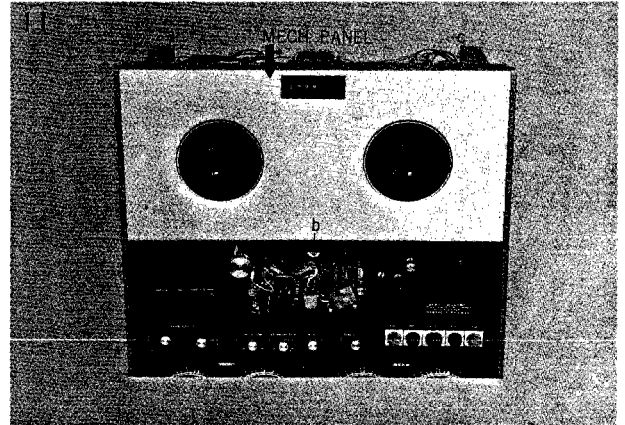
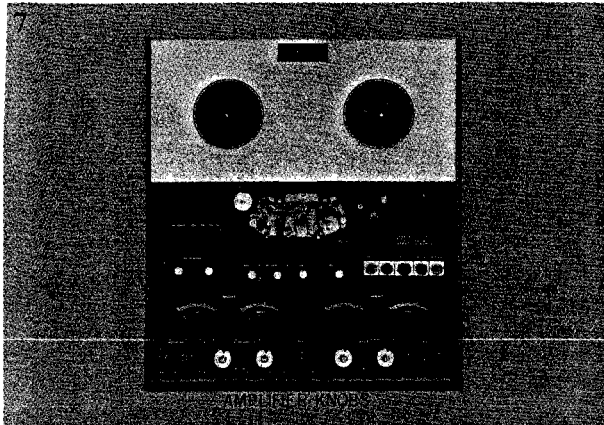

IV. TRANSPORT MECHANISM

1. SUPPLY VOLTAGE OF BOTH TORQUE MOTORS

	SUPPLY MOTOR	TAKE-UP MOTOR
Forward Playback	30 V	55 V
Reverse Playback	55 V	30 V
F.F.	100 V	12 V
RWD	12 V	100 V

Fig. 1

NOTE : These voltages values are approximate.

2. PINCH ROLLER PRESSURE

Proper pinch roller pressure is 1.2 kg (± 100 gr)

3. TRANSISTOR AND RELAY OPERATION CHART

Relay	PLAY	REV. 1	REV. 2	F.F	FAST	T.D	TRANSISTOR
Mode FORWARD	○						TR107, TR110
REV	○	○	○				TR107, TR111
F. FWD				○	○		TR105, TR106
RWD					○		TR105
FWD to REV	○	○	○			○	TR101, TR102, TR107, TR111
REV to FWD	○					○	TR101, TR102, TR107, TR110
F. FWD or RWD to FORWARD	○					○	TR103, TR104, TR107, TR110
F. FWD or RWD to REV	○	○	○			○	TR103, TR104, TR107, TR111

Fig. 2

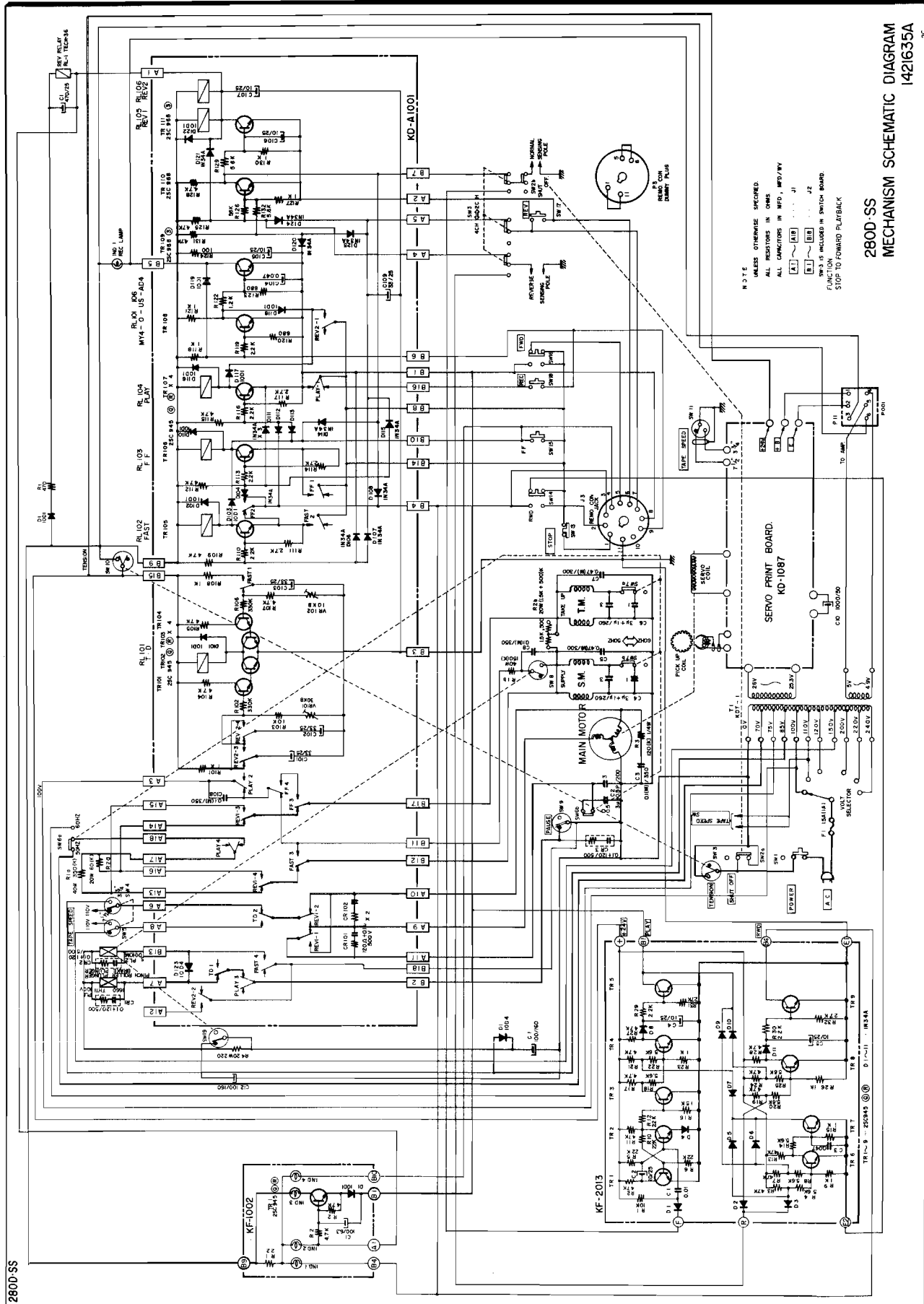
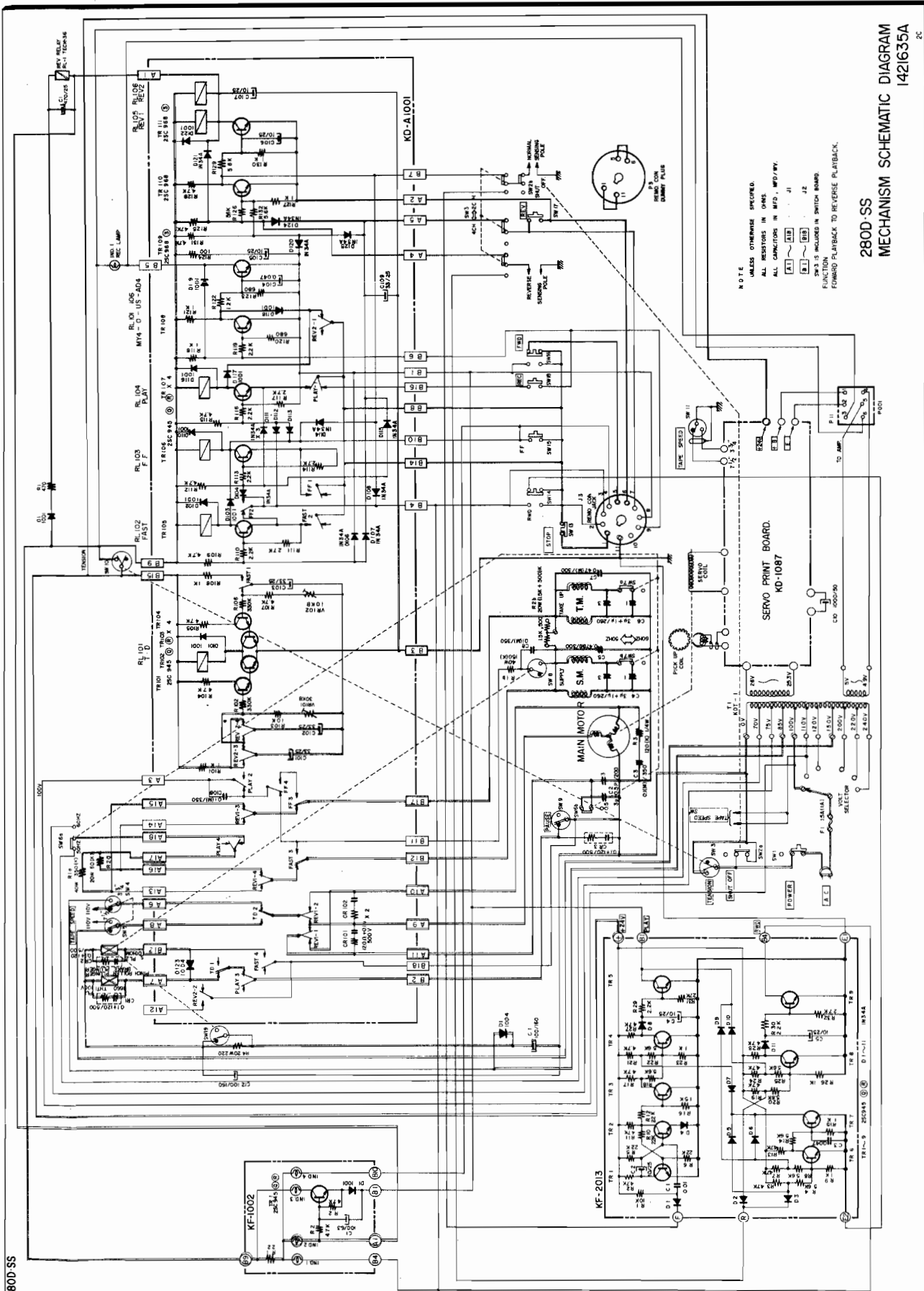

Fig. 3

280D SS



NOTE
 UNLESS OTHERWISE SPECIFIED
 ALL RESISTORS IN OHMS
 ALL CAPACITORS IN MFD, UNLESS NOTED OTHERWISE
 FUNCTION SW3 IS INCLUDED IN SWITCH BOARD.
 FORWARD PLAYBACK TO REVERSE PLAYBACK.

280D-SS
 MECHANISM SCHEMATIC DIAGRAM
 1421635A

Fig. 4

4. FROM STOP TO FORWARD PLAYBACK (RECORDING) (See Figs. 1, 2, and 3).

When the FWD Button is depressed, TR-107 emitter is grounded, and TR-107 passes R-104 and is turned on. TR-107 is maintained at "on" by RL-104 contact point Play-1.

The Pinch Roller Plunger and Brake Plunger current passes Play-3 and is turned on. The voltage passes Play 4 and is divided by means of R1A (350 Ω) and R2A (50 Ω). About 55 V is supplied to the Take-Up Motor and about 30 V to the Supply Motor. At 7-1/2 ips, 110 V is applied to the Main Motor and at 3-3/4 ips, 85 V is applied to the Main Motor.

At Forward Playback, TR-110 is turned on, and TR-111 is turned off. C-101 of T.D. Circuit passes R-101 and is charged.

5. 2-CHANNEL AUTOMATIC REVERSE PLAYBACK (See Figs. 1, 2 and 4)

a) From Forward to Reverse Playback.

When the Reverse Button is depressed or when the sensing tape passes the sensing pole, TR-110 is turned off and TR-111 is turned on. Consequently, RL-105, RL-106, and RL-1 of Switch Board is turned on. When RL-106 is momentarily turned on, C-101 passes R-103 and VR-101 and discharge begins. C-101 discharge current flows to the base of TR-101 and TR-102 and they are turned on. When this occurs, RL-101 is turned on, and Brake Plunger as well as Pinch Roller Plunger is turned off. At this time, the capstan motor begins reverse revolutions. (While RL-101 is "on", because increased torque is applied to the capstan motor, high voltage is applied).

When discharge of C-101 is completed, TR-101 and TR-102 are turned off. RL-101 is also turned off and voltage is supplied to the Pinch Roller Plunger as well as to the Brake Plunger and playback is effected.

b) From Reverse to Forward Play

When the FWD Button is depressed or the sensing tape passes the sensing pole, TR-111 is turned off, and TR-110 is turned on. Because TR-111 is turned off, RL-105 and RL-106 as well as RL-1 are turned off. When RL-106 is momentarily turned off, CR-102 passes RL-103 and VR-101 and discharge commences. C-102 discharge current flows to the base of TR-101 and TR-102 and they are turned on. When this occurs, RL-101 is turned on and the Brake Plunger as well as the Pinch Roller Plunger are turned off. At this time, the capstan motor begins forward revolutions. (While RL-101 is "on", because increased torque is applied to the capstan motor, high voltage is applied).

When discharge of C-102 is completed, TR-101 and TR-102 is also turned off and voltage is supplied to the Pinch Roller Plunger as well as to the Brake Plunger and Forward Playback is effected. Charge of C-101 is begun. (If Shut-Off Switch is at "on" position, this operation will not take place).

6. FAST FORWARD (See Figs. 1 and 2)

When the Fast Forward Button is depressed, current flows to RL-102 and RL-103. At the same time, TR-105 and TR-106 is maintained at "on", and Fast Forward operates. 100 V is applied to the Take-Up Motor and about 12 V to the Supply Motor.

When Fast Forward is effected from Forward Playback, DR-113 is activated and cuts off TR-107.

When Fast Forward is effected from Reverse Playback, D-114 is activated and cuts off TR-111.

When Fast Forward is effected from Rewind, TR-105 remains "on", TR-106 operates and RL-103 is turned on.

7. REWIND (See Figs. 1 and 2).

When the Rewind Button is depressed, TR-105 is turned on. TR-105 is maintained at "on" by means of RL-102. 100 V is applied to the Supply Motor and about 12 V to the Take-Up Motor.

When Rewind is effected from Forward Playback, D-112 is activated and cuts off TR-107.

When Rewind is effected from Reverse Playback, D-108 is activated and cuts off TR-111.

When Rewind is effected from Fast Forward, D-104 is activated and cuts off TR-106.

8. 4-CHANNEL REPEAT CIRCUIT (See Figs. 5 and 6)

When the Stereo Selector is set to 4-Channel position, Syscon Board **A7** and **A4** are opened. When during Forward Playback, the sensing tape passes the reverse sensing pole, TR-6 is turned off and TR-7 is turned on. At this time, TR-4 is "on" and TR-5 is turned off. Further, because TR-8 is "off" and TR-9 "on", **B4** is grounded and at the same time, TR-107 is turned off. TR-105 is turned on and because it passes RL-102 is held at "on". Consequently, Rewind mode is attained and the tape begins to rewind.

When the sensing tape passes the Forward sensing pole, D₁ is grounded, TR-1 is turned on, TR-2 is turned off, and TR-3 is turned on. Thus, TR-4 which has been on up to now is turned off and TR-5 is turned from off to on. Because TR-5 is on, the unit operates in the same way as if the Forward Button had been depressed (TR-107 is turned on, and TR-105 is turned off. Consequently,

Forward Play commences).
 Because sensing tape is affixed at both ends, repeat mode is continuous (Play-Rewind-Play).
 Rewind and Stop can be effected by depressing the Rewind Button during Repeat Mode. When the Rewind Button is depressed, TR-6 is turned on and TR-7 is

turned off. For this reason, TR-4 is maintained at "on". Although Pin D₁ is grounded, and TR-1 is turned on, TR-2 off, and TR-3 on, because TR-4 is held at "on", and TR-5 is turned off, the machine will not enter Forward Play.

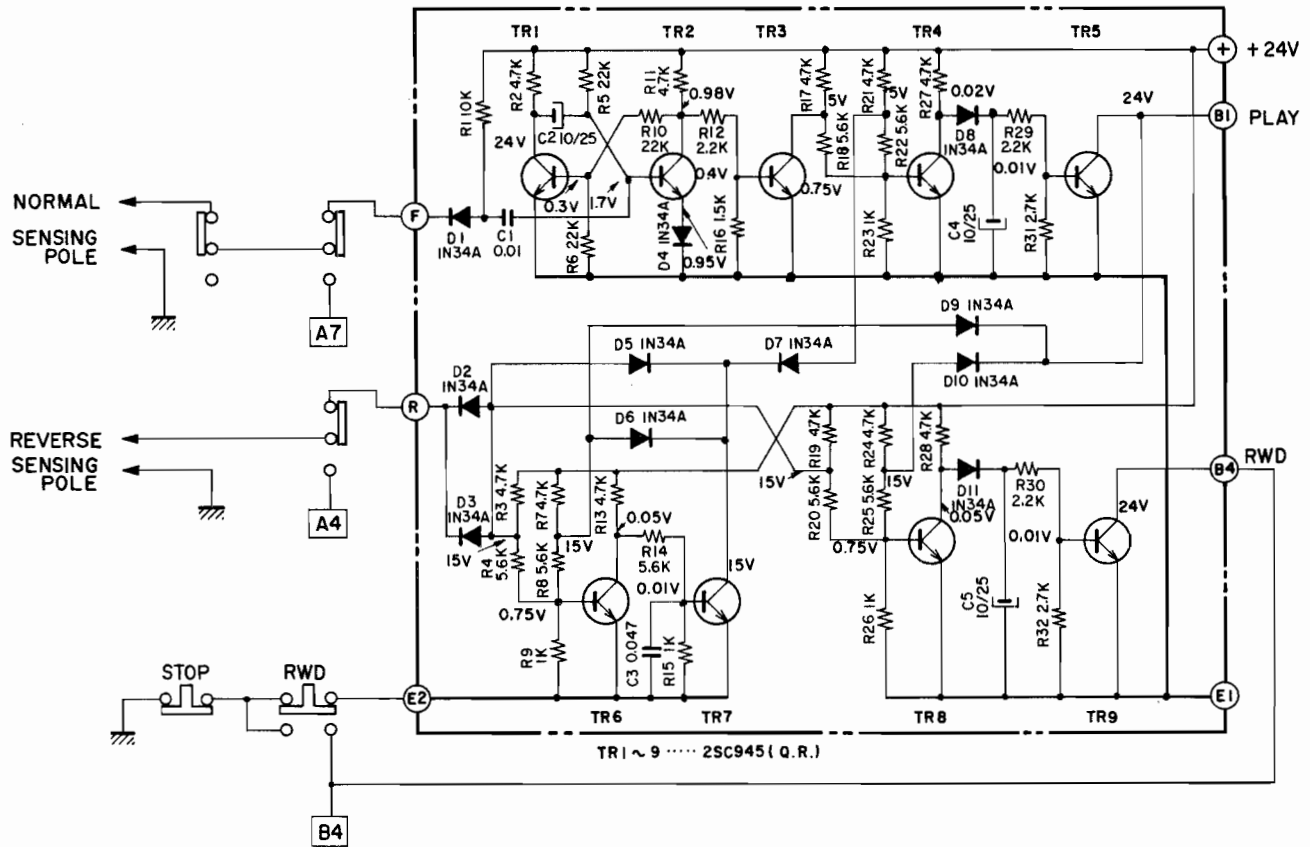

Fig. 5

4-CHANNEL REPEAT CIRCUIT

	TR105	TR107	TR1	TR2	TR3	TR4	TR5	TR6	TR7	TR8	TR9
Forward play	OFF	ON	OFF	ON	OFF	ON	OFF	ON	OFF	ON	OFF
Repeat (sensing tape passed Reverse sensing pole)	ON	OFF	OFF	ON	OFF	ON	OFF	OFF	ON	OFF	ON
Stop the Forward play (sensing tape passed Forward sensing pole)	OFF	ON	ON	OFF	ON	OFF	ON	OFF	ON	OFF	ON
(sensing tape passed Forward sensing pole)	OFF	ON	OFF	ON	OFF	ON	OFF	OFF	ON	ON	OFF

Fig. 6

9. SERVO-MOTOR OPERATING PRINCIPLES

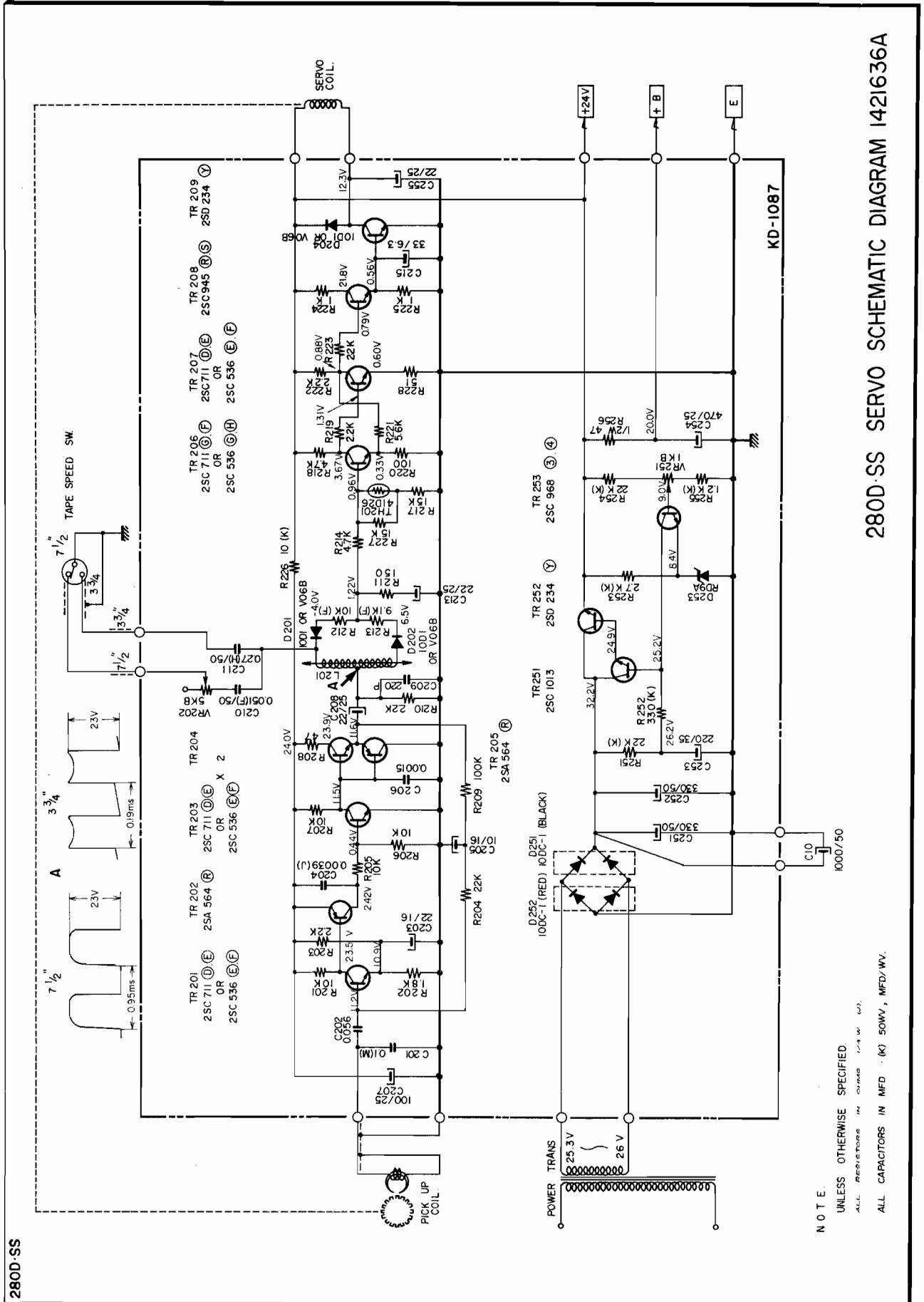

280D·SS SERVO SCHEMATIC DIAGRAM I421636A

NOTE.
UNLESS OTHERWISE SPECIFIED.
ALL RESISTORS IN OHMS 1/4 W. 1/2.
ALL CAPACITORS IN MFD. (K) 50WV, MFD/WV.

Fig. 7

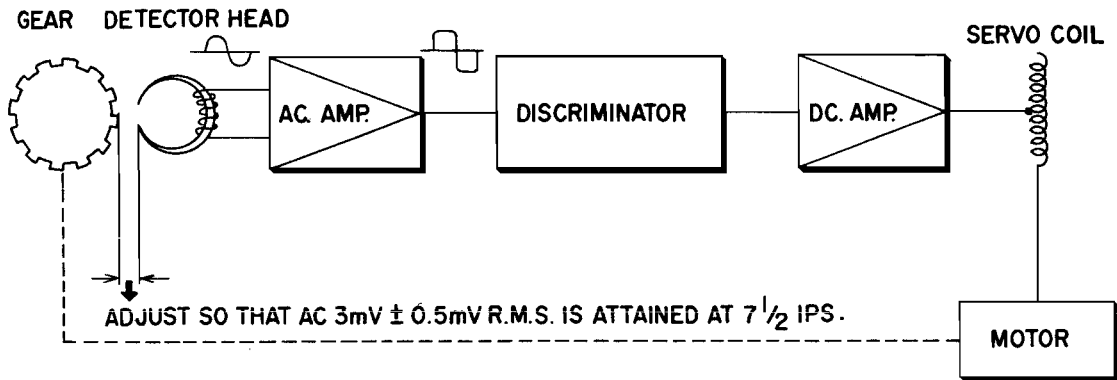

Fig. 8 Servo Circuit Block Diagram

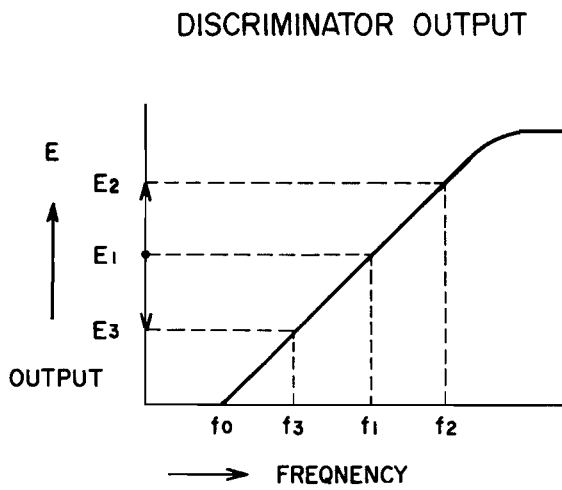

Fig. 9

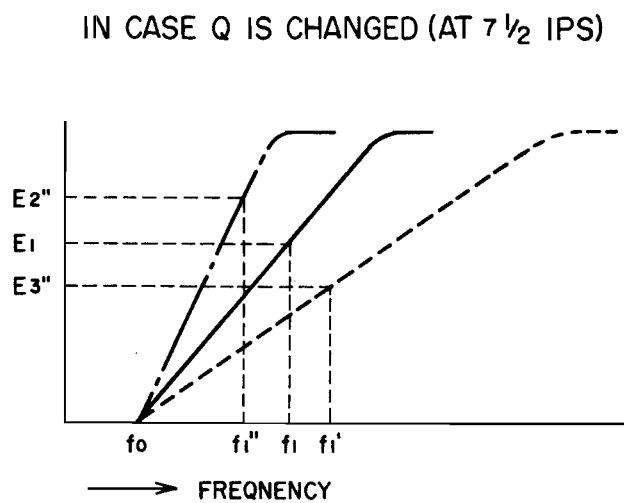

Fig. 11

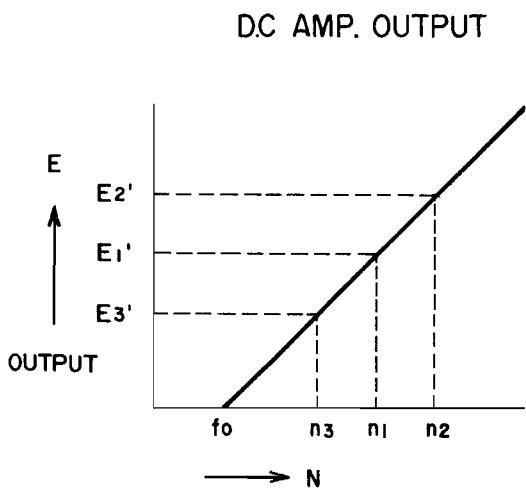

Fig. 10

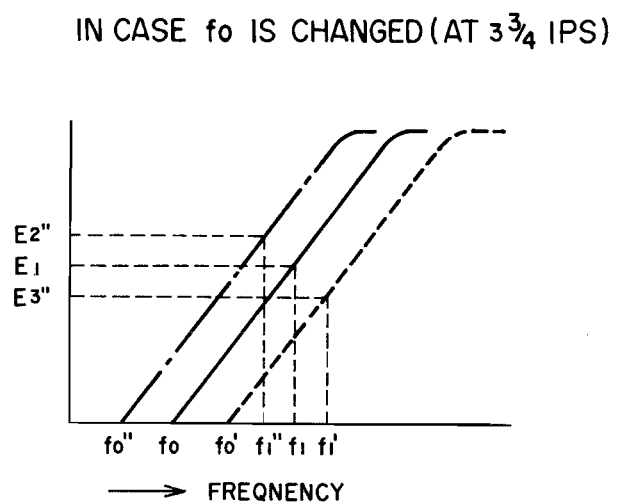

Fig. 12

- 1) When the gap between the gear, which is directly connected from the capstan motor revolutions to the motor (120 gear teeth), and the pick-up coil changes, voltage is generated at the pick-up coil and from this frequency, the motor revolutions are detected. When proper revolutions are reached, this frequency is referred to as f_1 .
- 2) This generated AC voltage (V_{f_1}) is amplified to saturation and supplied to the Discriminator.
- 3) The Discriminator is comprised of L-201 and C-210 (at 7-1/2 ips) (L201 and C-211 at 3-3/4) resonance circuit. This resonance frequency is referred to as f_0 .
(When the Speed Selector is switched, because the frequency of generated voltage at pick-up coil is changed, the various values of the Discriminator condensers are changed and f_0 is altered).
- 4) As shown in Fig. 9, the Discriminator emits an E_1 output which is the result of the f_1 frequency when motor revolutions are correct. This E_1 is amplified at DC Amp and is supplied to the Servo Coil. The motor revolutions at this time is referred to as n_1 and Brake Voltage E'_1 generates. The magnetic braking (produced by this E'_1) and load torque is balanced with motor torque and normal revolutions n_1 is maintained. (The main motor revolutions when no magnetic braking is applied is about 1460 r.p.m at 50 Hz, and about 1730 r.p.m at 60 Hz).
- 5) In case of certain influence resulting increased motor speed, the frequency detected by the pick-up

coil becomes slightly high. At this time, the frequency is referred to as f_2 . As shown in Fig. 9, the Discriminator output becomes larger than E_1 and E_2 output is emitted. As shown in Fig. 10, a DC Amp output of E_2' is obtained.

Because E_2' is larger than E_1' , a stronger than n_1 magnetic braking is applied for return to n_1 point.

- 6) If the motor speed is slow, the frequency detected by the pick-up coil is slightly low. At this time, the frequency is referred to as f_3 . As shown in Fig. 9, the Discriminator output becomes smaller than E_1 and E_3 output is emitted. As shown in Fig. 10, a DC Amp output of E_3' is obtained. Because E_3' is smaller than E_1' , the magnetic braking becomes weaker, and motor speed is increased for return to n_1 point. Thus, revolutions are stabilized and n_1 normal revolutions are maintained.
- 7) In order for n_1 to meet specified revolutions, it is necessary to adjust E_1 . f_0 is changed by adjusting L-201 dust core (See Fig. 12), Q of resonance circuit is changed by adjusting VR-202, and as shown in Fig. 11, the rise-up angle of S curve is altered.

Because of this, E_1 and between E_2'' and E_3'' at center are delicately changed, and E_1 is fixed at normal specified revolutions.

(Because, due to relationship to magnetic brake, motor self torque differs at 7-1/2 and 3-3/4 ips, the motor supply voltage changes).

	Motor Supply Voltage	Motor Voltage at beginning of Fwd or Rwd.	Pick-up coil Voltage	Pick-up coil Frequency	Motor Speed
7-1/2 ips	110 V	150 V	3 mV \pm 0.5 mV r.m.s.	About 1040 Hz	520 r.p.m.
3-3/4 ips	85 V	110 V	1.5 mV \pm 0.25 mV r.m.s.	About 520 Hz	260 r.p.m.

Fig. 13

10. 4-CHANNEL SURROUND STEREO SYSTEM

1). Head Construction

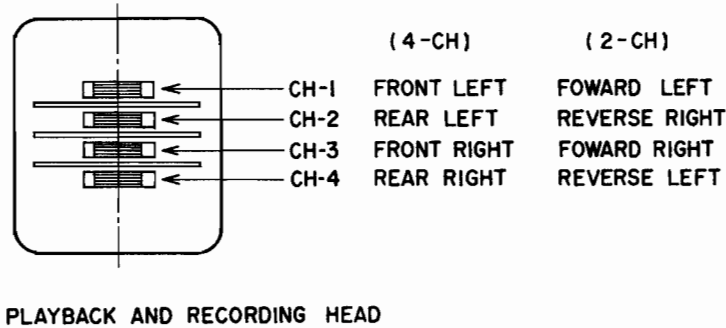

Fig. 14

2). ORDER OF HEADS

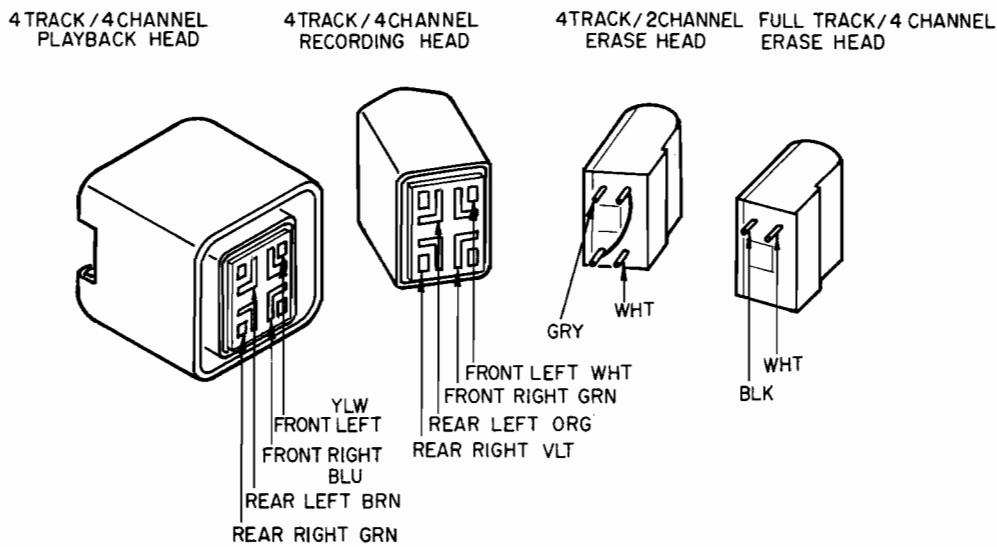
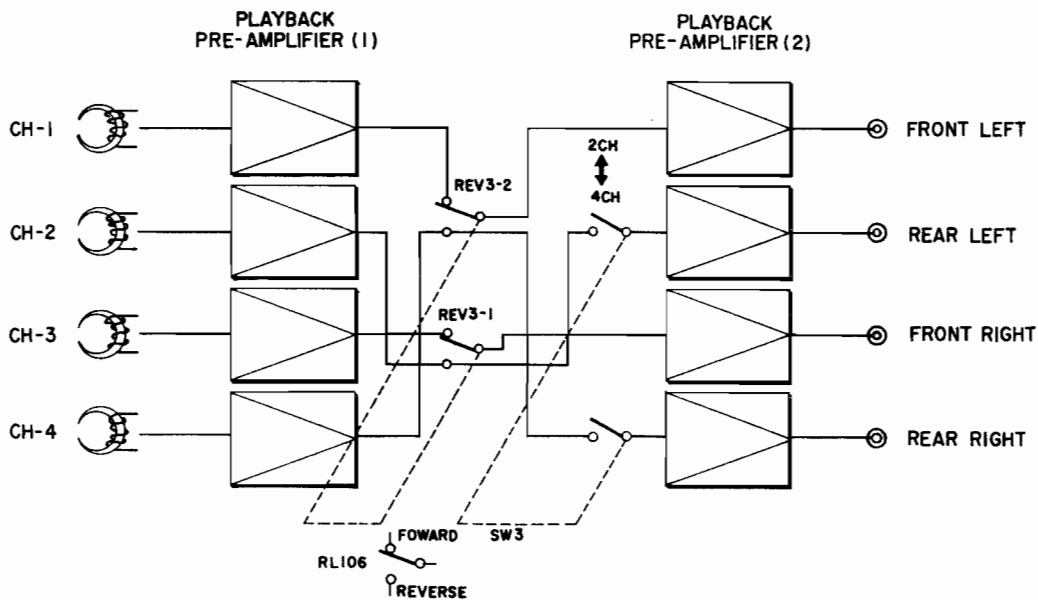

Fig. 15

3). Block Diagram when switched from 2-CH to 4-CH and 2-Channel Reverse Playback



NOTE: PLAYBACK PRE-AMPLIFIER (1) AND (2) IS SAME P.C. BOARD. (MS-5022)

Fig. 16

V. MECHANISM ADJUSTMENT

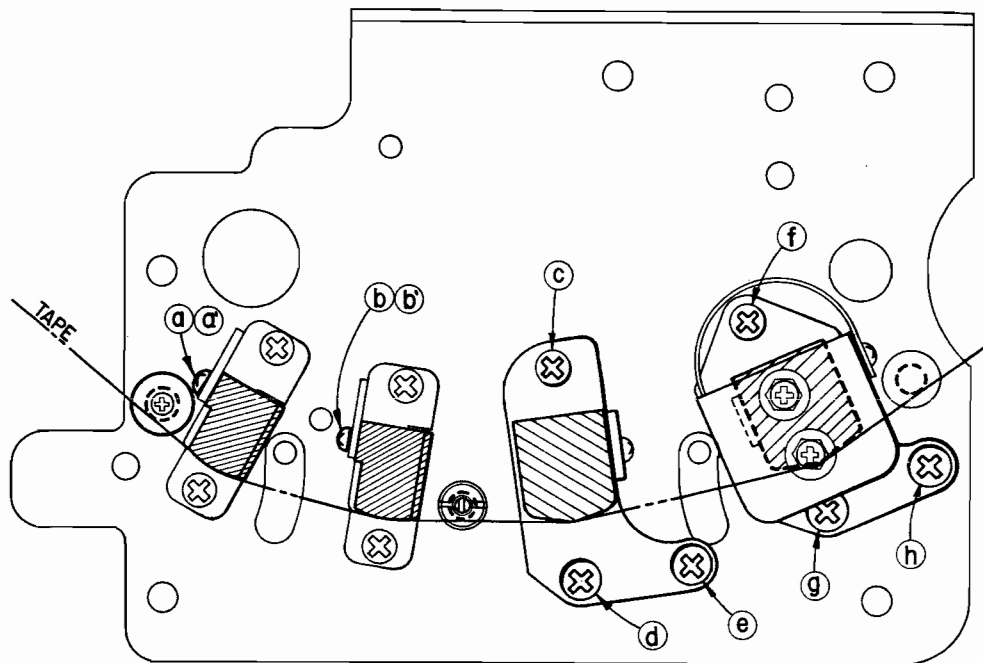

Fig. 17

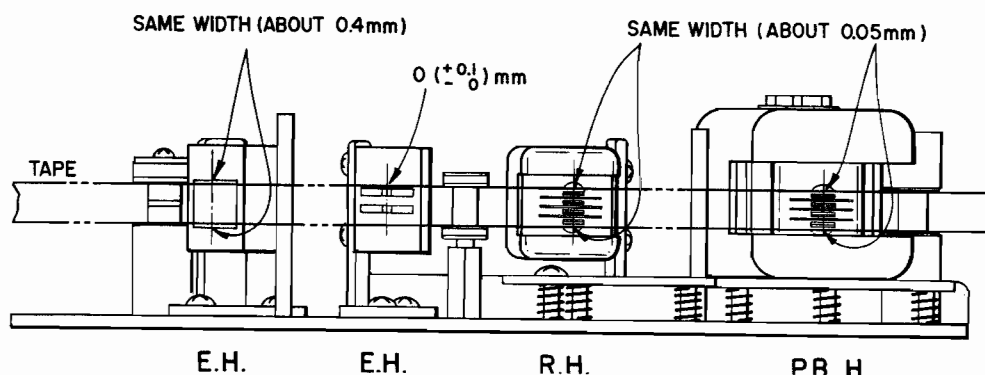

Fig. 18

1. ADJUSTMENT OF HEAD ALIGNMENT

A. Adjustment of Head Height (See Figs. 17 and 18)

- a) Erase Head (4-channel)
Loosen Full Track Erase Head Adjustment Screws (a) (a') and adjust so that the width of the head core on both sides of the tape are equal. (Core should protrude about 0.4 mm at both top and bottom).
- b) Erase Head (2-channel)
Loosen 2-Track Erase Head Height Adjustment Screws (b) (b') and adjust so that the upper edge of the head core and the upper edge of tape are the same height ($0 (+0.1/-0)$ mm).
- c) Recording Head
With Height Control Screws (c) (d), adjust so that the width between the upper edge of Track 1 head core and the upper edge of the tape is equal to the width between the lower edge of track 4 head core and the lower edge of the tape (about 0.05 mm).
- d) Playback Head
With Height Control Screws (f) (g), adjust so that the width between the upper edge of the tape is equal to the width between the lower edge of Track

1 head core and the upper edge of Track 4 head core and the lower edge of the tape (about 0.05 mm).

B. Adjustment of Head Slant (See Figs. 17 and 18)

Adjust Screws (c) (d) and (f) (g) so that the tape makes perfect contact with the various heads (recording and playback heads).

If Head Slant Adjustment causes a shift in head height positions, readjust head height.

C. Adjustment of Head Azimuth (See Figs. 17 and 18)

- a) Playback Head
Play back a pre-recorded tape (8,000 Hz) at 3-3/4 ips and connect a High Sensitivity V.T.V.M. to the line output. Then, turn Azimuth Control Screw (h) until the output level of both channels reaches maximum.
- b) Recording Head
At recording mode, supply a 8,000 Hz. sine wave at a -10 dB recording level from an Audio Frequency Oscillator to the line input and set the Monitor Switch to "Tape" position. Connect a High Sensitivity V.T.V.M. to the line output. Then, turn Azimuth Control Screw (e) until the output of both channels reaches maximum.

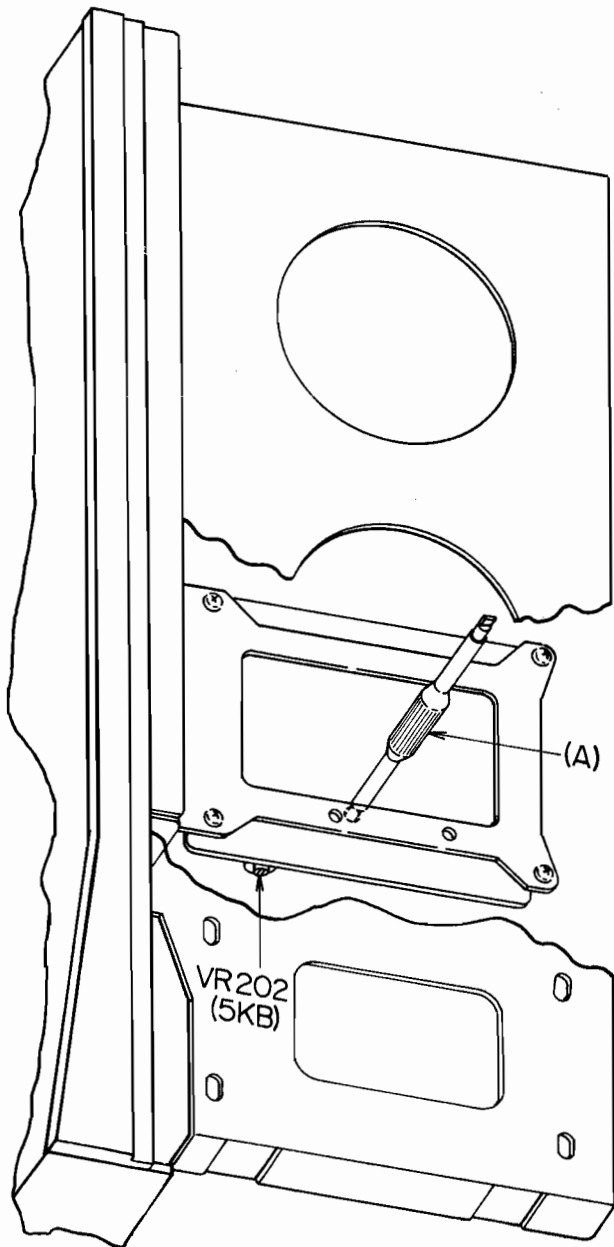

Fig. 19

2. TAPE SPEED ADJUSTMENT METHODS

(See Fig. 19)

(Servo-Motor Circuit Adjustment)

Measuring Method Involving Use Of Pre-recorded Tape

- Set Tape Speed Selector to 3-3/4 ips and playback a 1 KHz pre-recorded tape.
- Connect a Frequency Counter to the line output.
- Adjust L-201 in transformer core so that the Frequency Counter indication is 500 Hz ($\pm 1\%$).
- Set Tape Speed Selector to 7-1/2 ips.

Adjust VR-202 (5 KB) so that the Frequency Counter indication is 1,000 Hz. (+1.0/-0.5%)

Motor revolutions at each speed should be as follows :

7-1/2 ips 520 r.p.m.

3-3/4 ips 260 r.p.m.

In case a Frequency Counter is not available, connect an oscilloscope to the center point of L201 and measure the respective waveforms (Refer to Servo Motor Operating Principles Fig. 7).

3. ADJUSTMENT OF FORWARD ↔ REVERSE TIME CONSTANT (See Fig. 20)

The Time Constant when switching to and from Forward and Reverse Play is adjusted with System Control Board VR-101 (30 KB). About 3 seconds is ideal.

4. ADJUSTMENT OF FAST FORWARD OR REWIND TO FORWARD OR REVERSE PLAYBACK (See Fig. 20)

The various Time Constants when switching from Fast Forward or Rewind to Forward or Reverse Play are adjusted with System Control Board VR-102 (10 KB). About 1.5 seconds is ideal.

During Fast Forward or Rewind operation, Relay Contact Point "Fast 1" charges C-103. When Fast 1 is turned off, C-103 discharge turns on TR-103 and TR-104 and RL-101 (T.D.) is activated. When C-103 is completely discharged, RL-101 is turned off.

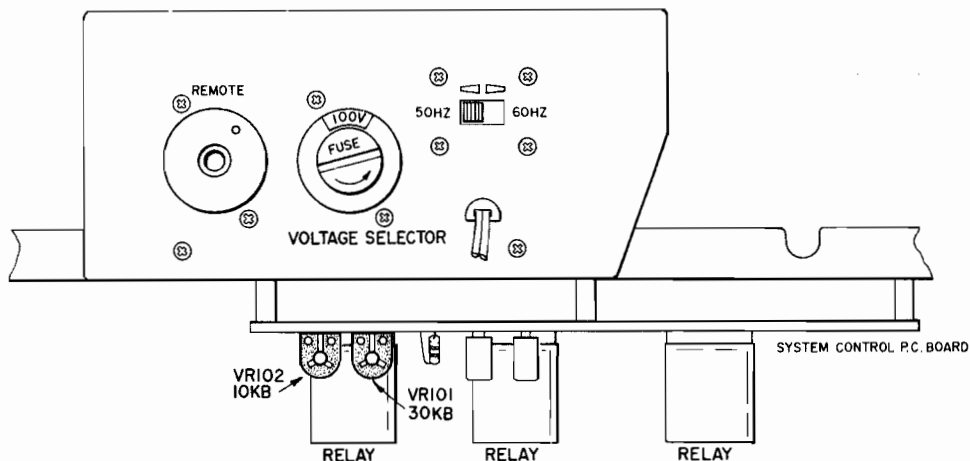

Fig. 20

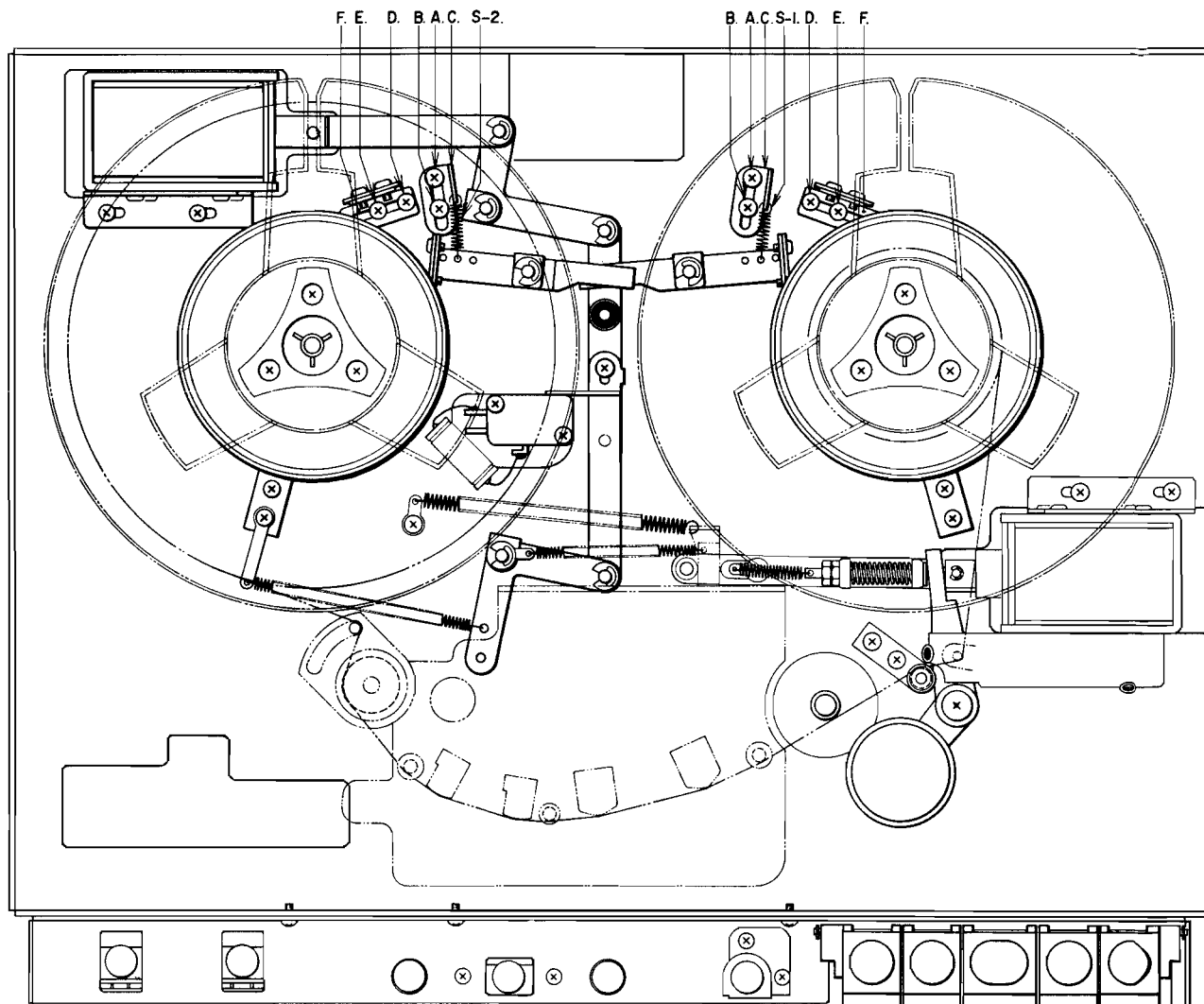

Fig. 21

5. BRAKE TENSION ADJUSTMENT (See Fig. 21)

For Brake Tension Measurement, use a 60 mm tape wound on a 5" reel and measure with a Tension Gauge. Standard tension is about 350 grams. Adjust Brake Tension by changing position of suspended springs (S 1 and S 2 in Fig. 22), loosening screws (A) and (B) and changing position of spring suspension metal (C), or loosening screws (D) (E) and changing position of F.

Caution : Following Brake Adjustment, confirm that the Brake Band does not touch the cloth tape on brake drum (See Fig. 22).

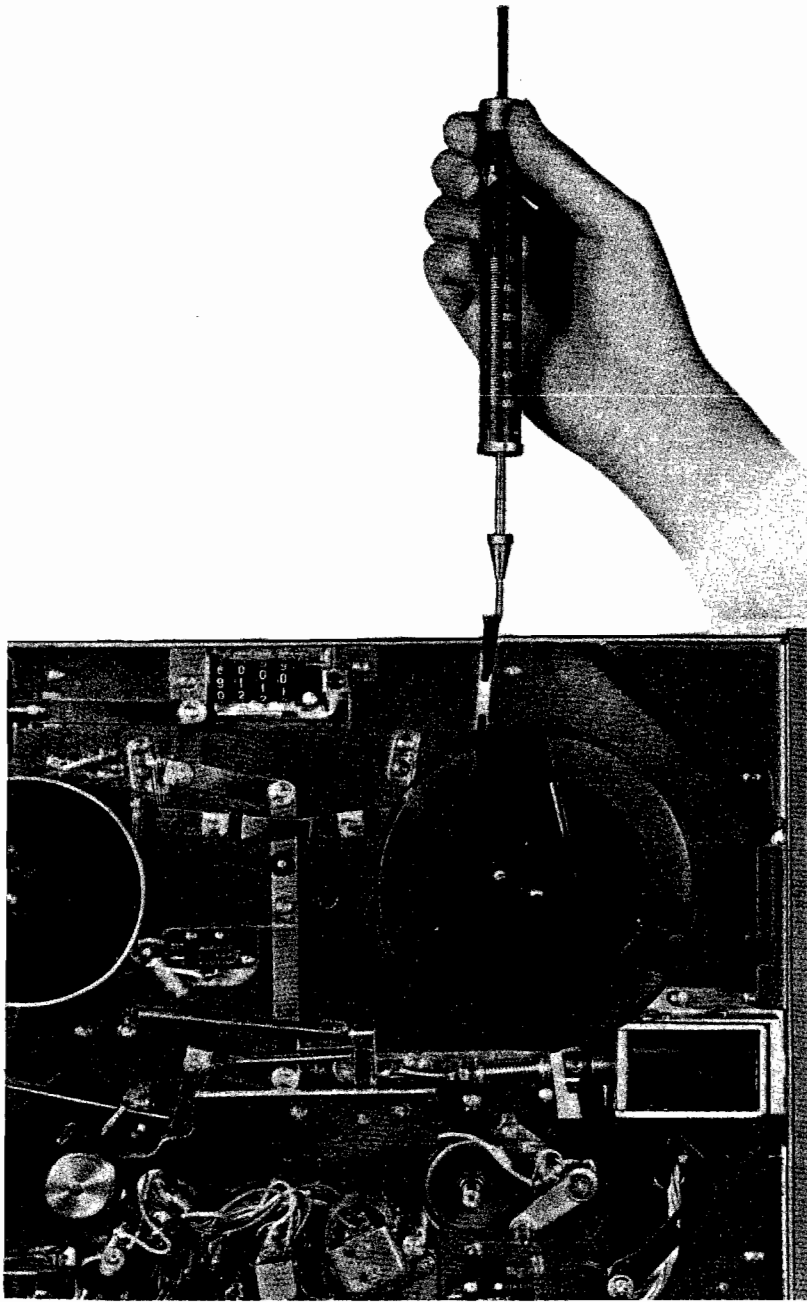

Fig. 22

6. REEL HEIGHT ADJUSTMENT (See Diagram Illustration)

Loosen Reel Table Adjusting Screws and regulate height.

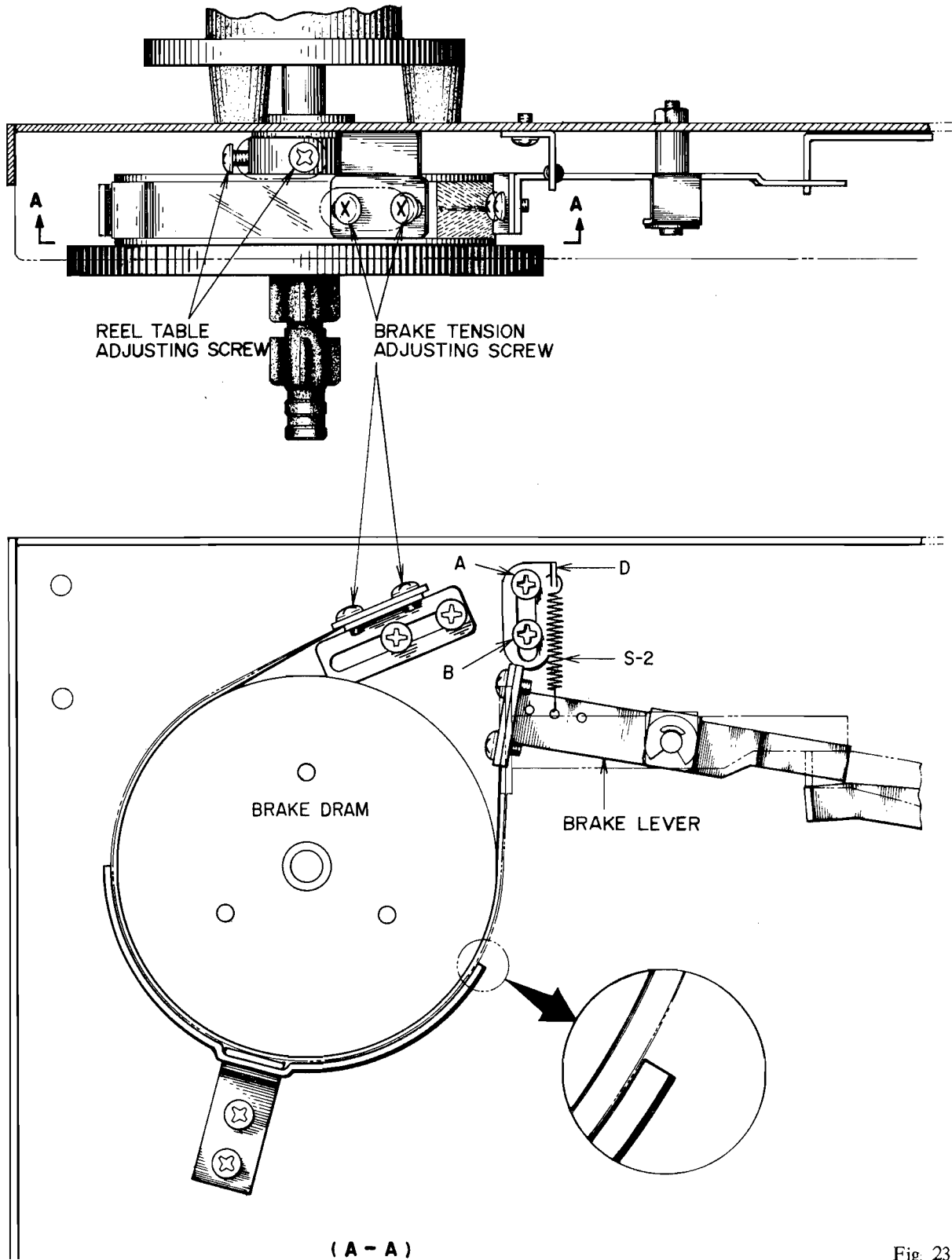

Fig. 23

VI. AMPLIFIER ADJUSTMENT

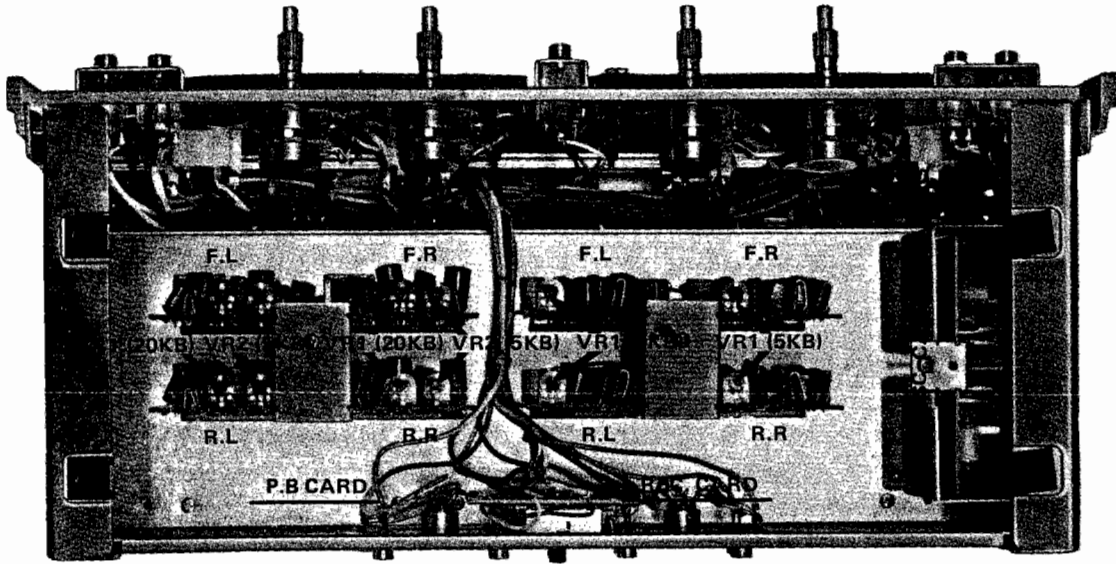

Fig. 24

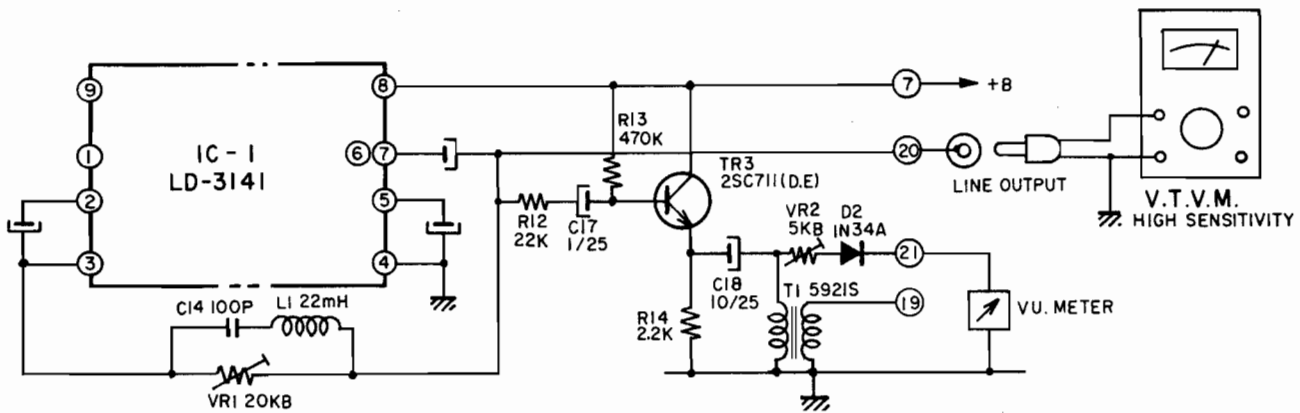

Fig. 25

1. ADJUSTMENT OF LINE OUTPUT LEVEL

A. Playback (See Figs. 24 and 25).

- Connect a high sensitivity V.T.V.M. to the Line Output Jack.
- Set the Tape Speed Selector Switch to "7-1/2" position.
- Set the Channel Selector to "4-CH" position.
- Play back a 250 Hz. pre-recorded tape.
- Adjust VR-1 (semi-fixed resistor 20 KB, Fig. 24) of playback amplifier so that the line output voltage is 1.228 V (+4 dB \pm 1.5 dB).
- Adjust VR-2 (semi-fixed resistor 5 KB, Fig. 24) of playback amplifier so that the VU Meter indicates "0" VU.

B. Recording and Playback (See Figs. 24 and 26)

- As shown in Fig. 26, connect an Audio Oscillator to the Line Input. Connect a high sensitivity V.T.V.M. to the Line Output.
- Set Tape Speed Selector to "7-1/2" position.
- Load a blank test tape "AKAI 100L" (FUJI S-100) on the tape recorder and set Monitor Switch to "Source" position.
- Feed in a 1,000 Hz. sine wave signal from an Audio Frequency Oscillator to the Line Input of the 280D-SS and turn Recording Line Level Control VR1 (50 KA) until the line output level reaches "0" VU (+4 dB).
- Depress "REC" Button and set machine to recording mode (run tape).
- Set Monitor Switch to "Tape" position and turn Recording Line Level Control VR1 (50 KA) again until the line output level reaches "0" VU.
- Set Monitor Switch to "Source" position again and turn Volume Control VR-1 (5 KB) until the line output level reaches "0" VU.
- Repeat twice in the same way as indicated in items f) and g) above.

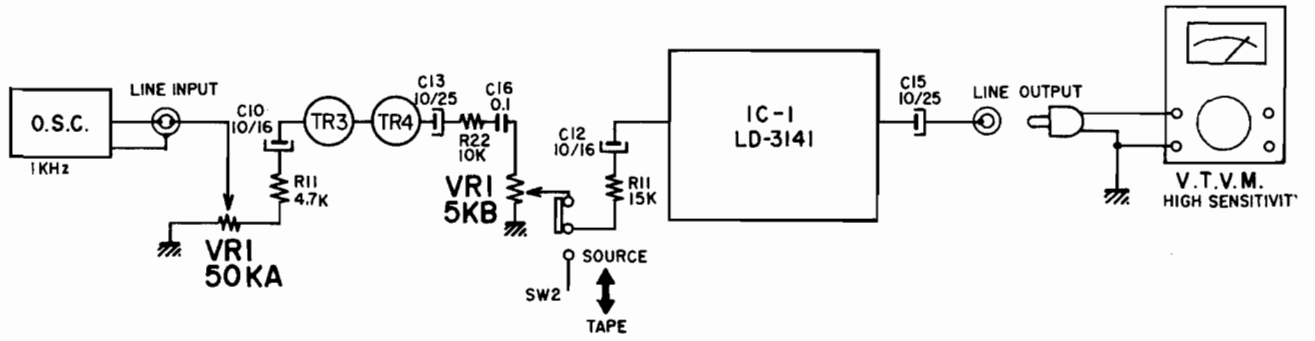

Fig. 26

2. RECORDING BIAS FREQUENCY ADJUSTMENT (See Figs. 27 and 28).

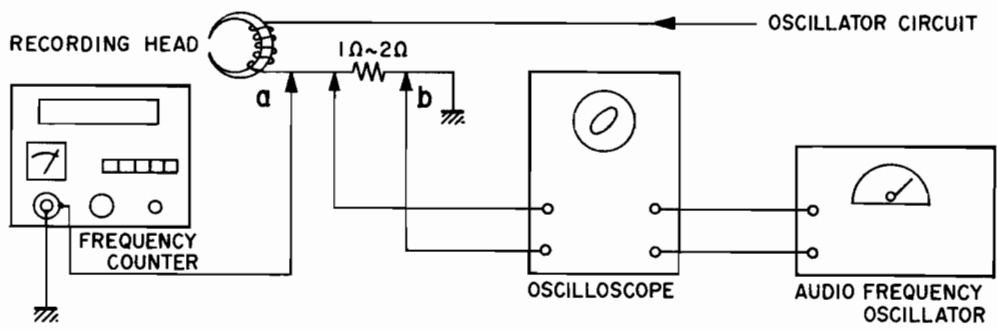

Fig. 27

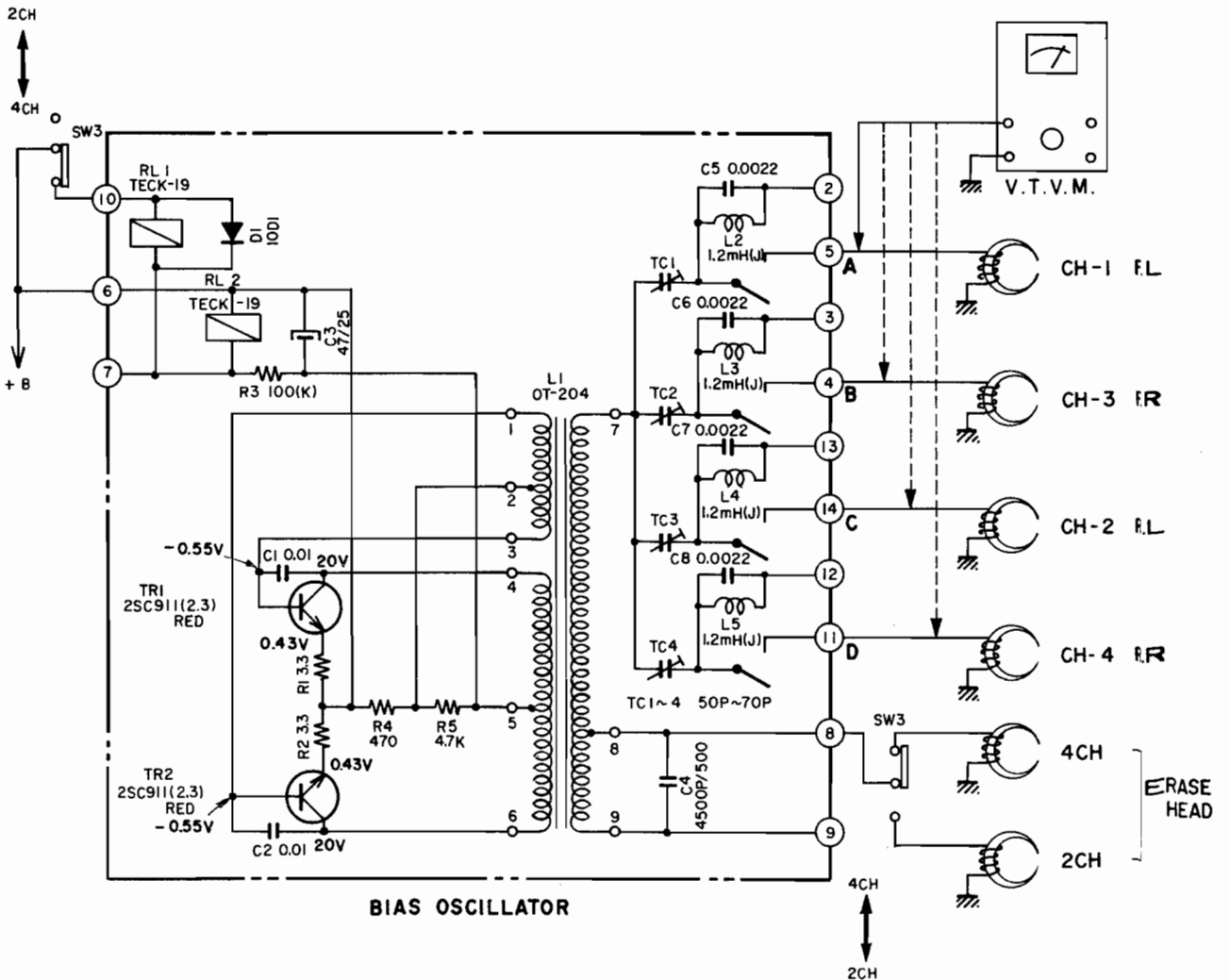

Fig. 28

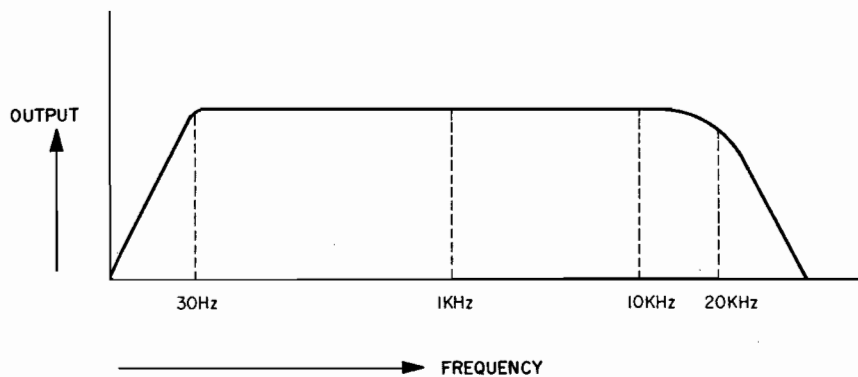

Fig. 29

Part I

- a) Install a resistor of 1 or 2 ohms in series with the Recording Head and connect the Vertical Input Terminal of the Oscilloscope to points (a) and (b).
- b) Feed in a sine wave signal from an Audio Frequency Oscillator to the Horizontal Input of the Oscilloscope and tune the dial of the Audio Frequency Oscillator until the Oscilloscope displays a circular or linear pattern.
- c) A reading of 100 KHz to 110 KHz (4-channel operation) indicates that the Recording Bias Frequency is correct.
- d) For correction of the Recording Bias Frequency, adjust the value of C-4 (4500 p).

Part II

- a) If a Frequency Counter is available, connect Frequency Counter Output Lead between (a) and (b) in Fig. 4 and read indication.

3. RECORDING BIAS VOLTAGE ADJUSTMENT

(FREQUENCY RESPONSE ADJUSTMENT,)

(See Figs. 28 and 29)

- a) Follow the Frequency Response Measuring Method.
- b) Supply a 1 KHz Input from an Audio Oscillator and adjust to "0" VU.
- c) Lower VU Level from 0 dB to -16 dB by means of an Attenuator.
- e) Connect a high sensitivity V.T.V.M. to the Line Output.
- f) Play back the 1 KHz and 10 KHz recorded signals and adjust Bias Voltage Adjusting Variable Capacitors TC-1 to TC-4 so that the output of both signals are equal.

Bias Voltage is about 13 to 18 volts. Proper frequency response at 3-3/4 ips and 7-1/2 ips is dependent upon these adjustments. (Frequency response will vary according to type of tape used).

Note: There is no way of adjusting the Erasing Bias Voltage, but correct voltage is between AC 65 and 75 volts.

VII. TROUBLE SHOOTING CHART

SECTION "A" TROUBLE WITH TRANSPORT MECHANISM

SYMPTOM	REMARKS
No power even when power switch is turned on.	<ol style="list-style-type: none"> 1. Check position of Auto Shut-Off Switch. 2. Fuse disconnected.
Capstan rotates during playback mode, but there are no reel motor revolutions.	<ol style="list-style-type: none"> 1. Faulty F.F. or FAST Relay contact point. 2. R1A (350 Ω) or R2A (60 Ω) disconnected. 3. Torque motor itself defective.
<p>Faulty reverse operation (does not reverse from forward mode)</p> <p>(does not forward from reverse mode)</p>	<ol style="list-style-type: none"> 1. Check reverse sensing pole. 2. Check TR-110 (2SC968) and TR-111 (2SC968) 3. Check Relay RL-105 and RL-106. 4. D-121 defective. <ol style="list-style-type: none"> 1. Check reverse sensing pole 2. Check TR-110 and TR-107. 3. Check Relay RL-104.
Does not Rewind	<ol style="list-style-type: none"> 1. Rewind operation switch (SW-14) defective. 2. Supply reel motor defective. 3. Check AC voltage. 4. Relay RL-102 (FAST) defective. 5. Check TR-105 (2SC945). 6. Accumulation of dust particles on tape surface.
Does not Fast Forward	<ol style="list-style-type: none"> 1. F.Fwd operation switch (SW-15) defective. 2. Take-up reel motor defective. 3. Check AC power voltage. 4. Relay RL-102 (FAST) and RL-103 (F.F) defective 5. Check TR-106 (2SC945)
Faulty Brake Operation	<ol style="list-style-type: none"> 1. Brake solenoid defective. 2. Faulty contact point Relay RL-104 (play) or RL-102 (FAST). 3. D-123 (10 D4) defective. 4. Brake band adjustment faulty.
Wow/Flutter	<ol style="list-style-type: none"> 1. Check to see whether brake shoe is touching reel table. 2. Check Pinch Roller Pressure. 3. Excessive torque motor vibration. 4. Main motor revolutions faulty.
<p>Faulty Repeat operation (does not reverse direction when sensing tape passes sensing pole) 4-channel only</p>	<ol style="list-style-type: none"> 1. Faulty contact of sensing tape and sensing pole. 2. Check repeat circuit transistor TR-8 and TR-9. 3. Check repeat circuit Diode D2 and D11.
During Repeat Mode, when tape is rewound, it stops and does not enter forward play.	<ol style="list-style-type: none"> 1. Faulty contact of sensing tape and sensing pole. 2. Check repeat circuit Diodes D1, D7, and D8. 3. Check repeat circuit transistors TR-1 to TR-5 and TR-7. 4. Rewind Button (Micro SW) faulty contact.
Squeaking noise when playing tape	<ol style="list-style-type: none"> 1. Deposit of dust on heads. 2. Recording tape is being charged with static electricity. 3. Head surface excessively heated after continued operation. 4. Worn out tape 5. Inferior quality tape.

SECTION "B" TROUBLE WITH MAIN (SERVO) MOTOR

SYMPTOM	REMARKS
<p>Incorrect motor revolutions</p> <p>(Discriminator L-201 center point waveform normal) (See Servo-Motor operating principle, Fig. 7)</p> <p>(Discriminator L-201 center point waveform abnormal)</p>	<ol style="list-style-type: none"> 1. Tape speed adjustment faulty. (See adjustment procedure). 2. Motor coil defective 3. Motor condenser defective 4. Check B+ (24 V) Voltage <ol style="list-style-type: none"> 2. Check voltage of DC Amp (TR-206 to TR-209) 2. Check D-201 and D-202. 3. Check Servo Coil. <ol style="list-style-type: none"> 1. Check voltage of AC Amp (TR-201 to TR-205) 2. Pick-up coil defective. 3. L-201 defective 4. Faulty adjustment of gap between motor gear and pick-up coil (Refer to Servo Motor Operating Principle).

SECTION "C" TROUBLE WITH AMPLIFIER

1. PLAYBACK MODE

SYMPTOM	REMARKS
<p>No sound from Line Output Jack (No B+ voltage supply)</p> <p>(B+ voltage supply)</p>	<ol style="list-style-type: none"> 1. Check Diodes D-251 and D-252. 2. Check Transistors TR-251 to TR-253 <ol style="list-style-type: none"> 1. Check voltage of playback card (MS-5022). 2. Check working order of transistors TR-1, TR-2 and TR-3 and IC-1 (LD-3141) on MC-5022. 3. Playback Head defective.
<p>Will play, but volume insufficient (B+ voltage low)</p> <p>(B+ voltage normal)</p>	<ol style="list-style-type: none"> 1. Check voltage of power supply circuit (KD-1087) <ol style="list-style-type: none"> 1. Oxide deposits accumulated on head. Clean head. 2. Playback head defective.
<p>Humming Noise (when playback head is grounded noise decreases)</p> <p>(grounding playback head does not alter hum)</p>	<ol style="list-style-type: none"> 1. Playback head defective. <ol style="list-style-type: none"> 1. Check transistor TR-253 on KD-1087. 2. Check condensers C-251 to C-254 and C-10.
<p>Sound Distorted</p>	<ol style="list-style-type: none"> 1. Oxide accumulated on playback head. 2. Check B+ voltage. 3. Check voltage of playback card (MS-5022) 4. Playback head worn out.
<p>Hissing Noise</p>	<ol style="list-style-type: none"> 1. Check TR-1, TR-2, and IC-1 (LD-3141) on playback card (MS-5022) 2. Head magnetized. 3. Defective Playback Coil.
<p>Sound drop-out</p>	<ol style="list-style-type: none"> 1. Tape old or defective. 2. Component connections poor contact.

SYMPTOM	REMARKS
Irregular Scratching or Crackling noise	1. Check transistors TR-1 and TR-2 and IC-1 (LD-3141) on playback card (MS-5022)
Lack of Treble	1. Oxide deposits collected on playback head surface. 2. Discrepancy in playback head azimuth alignment. 3. Head worn out.
Considerable difference between left and right (front or rear) levels during playback	1. Playback level out of adjustment

2. RECORDING MODE

SYMPTOM	REMARKS
Does not record (4-channel or 2-channel) (No VU Meter indication)	1. VU Meter itself or lead wire defective. 2. Defective input jack. 3. Check voltage of recording card (MS-5023)
(VU indication normal)	1. Check transistors TR-108 and TR-109 on system control. 2. Check Relay RL-1 and RL-2 on oscillator circuit (KF-5010) 3. Components of oscillator circuit or oscillator coil defective. 4. Recording head defective.
Sound Distorted (VU Meter functions normally. Also functions normally when monitor switch is at "source" position.	1. Faulty recording bias voltage. 2. Defective recording equalization circuit. 3. Dirty head.
Faulty erasing (4-channel or 2-channel) (Does not erase at all)	1. Erase head defective. 2. Disconnected erase head wire. 3. Components of oscillator circuit or oscillator coil defective.
(Incomplete erasure)	1. Erasing bias voltage low (check oscillator circuit) 2. Erase head defective.
Erasing Noise (popping noise)	1. Defective recording. 2. Transistor TR-1 or TR-2 or KF-5010 defective. 3. Head magnetized.
Recording sensitivity low (UV Meter functions normally)	1. Dirty head 2. Bias voltage out of adjustment 3. Tape itself defective.
(VU meter does not indicate properly)	1. Loose input jack connection 2. VU Meter sensitivity low. 3. Recording level out of adjustment.
Considerable difference between left and right (front or rear) levels when recording	1. Recording level out of adjustment.

VIII. COMPOSITE VIEWS OF COMPONENTS

SYSTEM CONTROL P.C. BOARD (KDA-1001A)

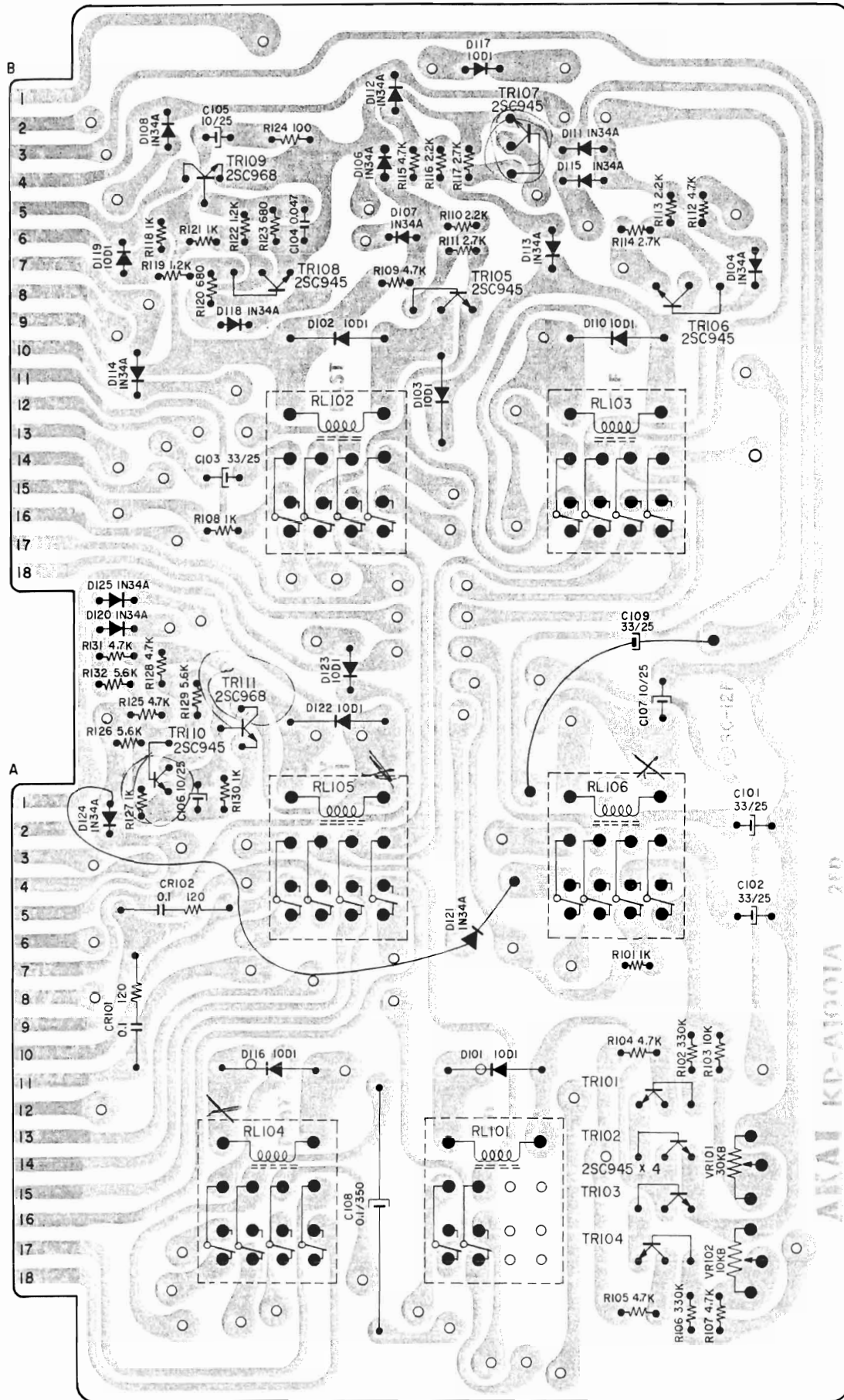

SERVOMOTOR CONTROL P.C. BOARD (KD-1087)

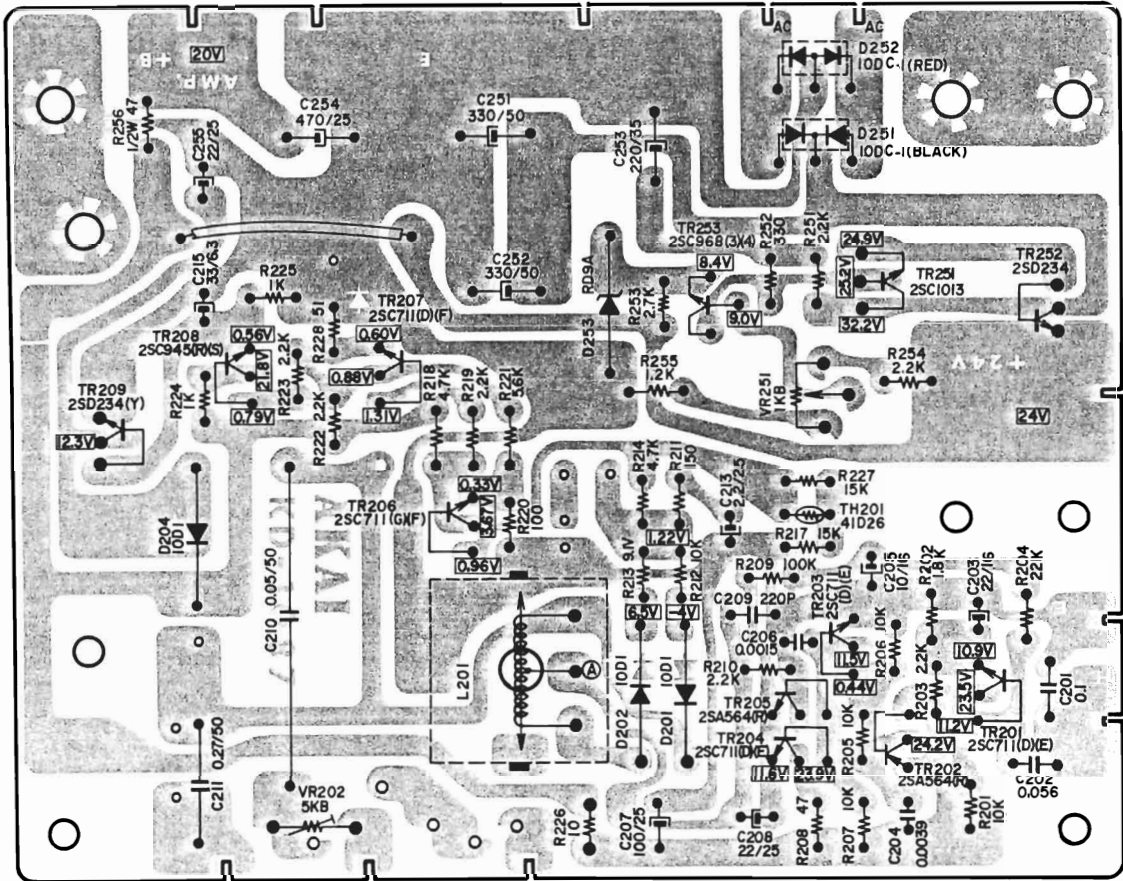

OSCILLATOR P.C. BOARD (KF-5010)

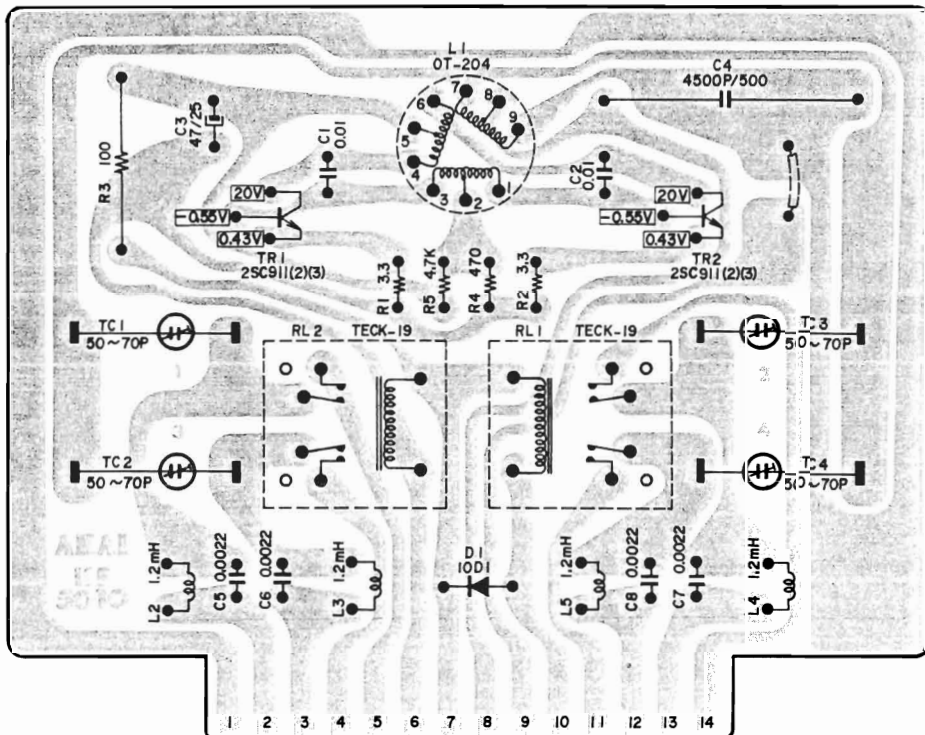

RECORDING AMP. P.C. BOARD (MS-5023)

TR1A,1B, 2A,2B,3A,3B,---2SC458(LG) TR4A,4B,---2SC711 TR5A,5B,---2SC968(2)(3)

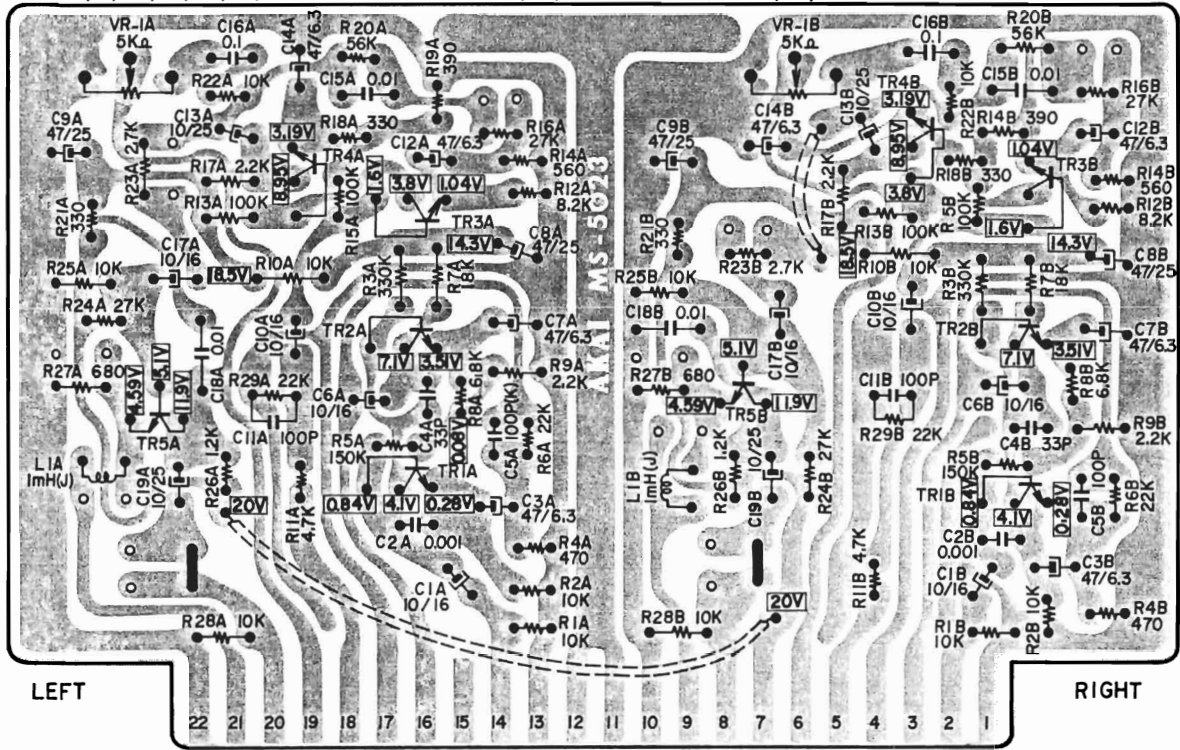

PLAYBACK AMP. P.C. BOARD (MS-5022)

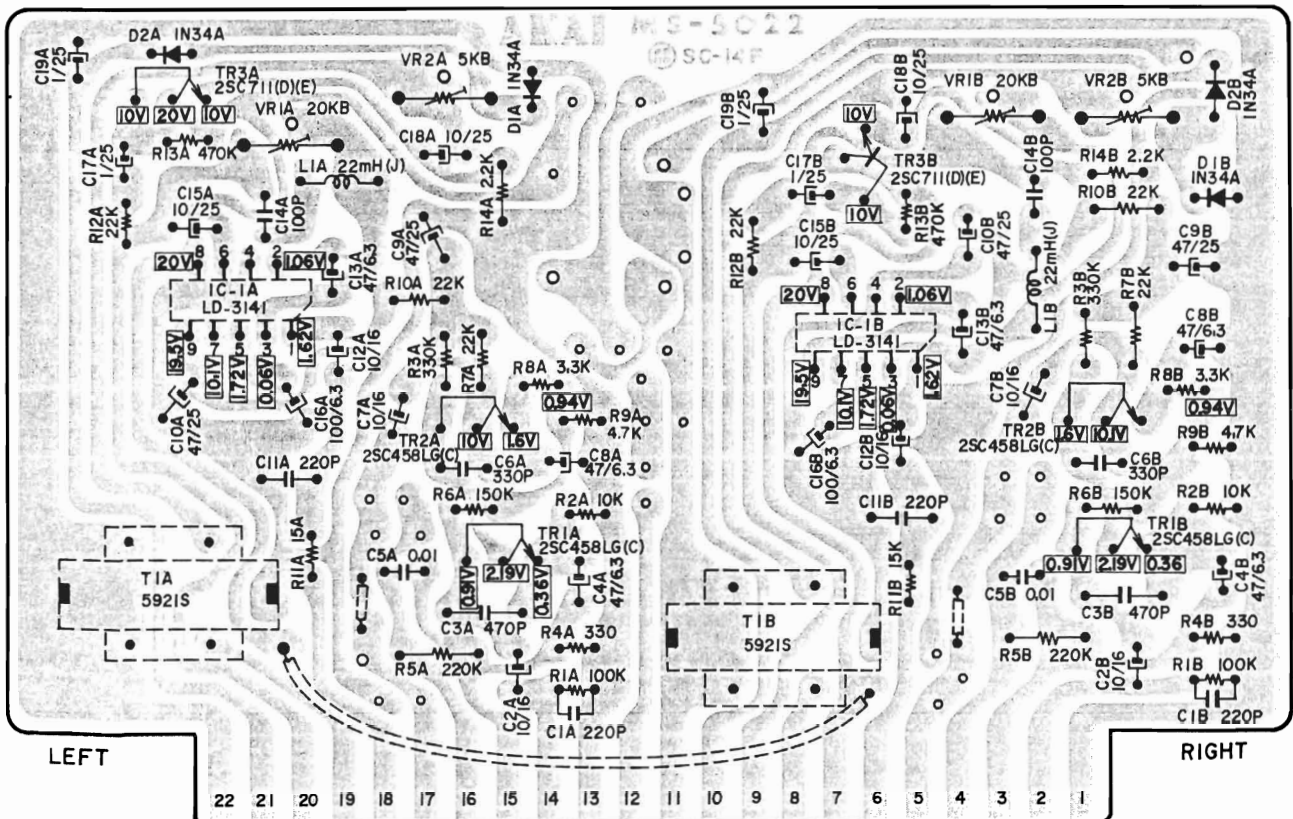

AUTOMATIC REPEAT P.C. BOARD (KF-2013)

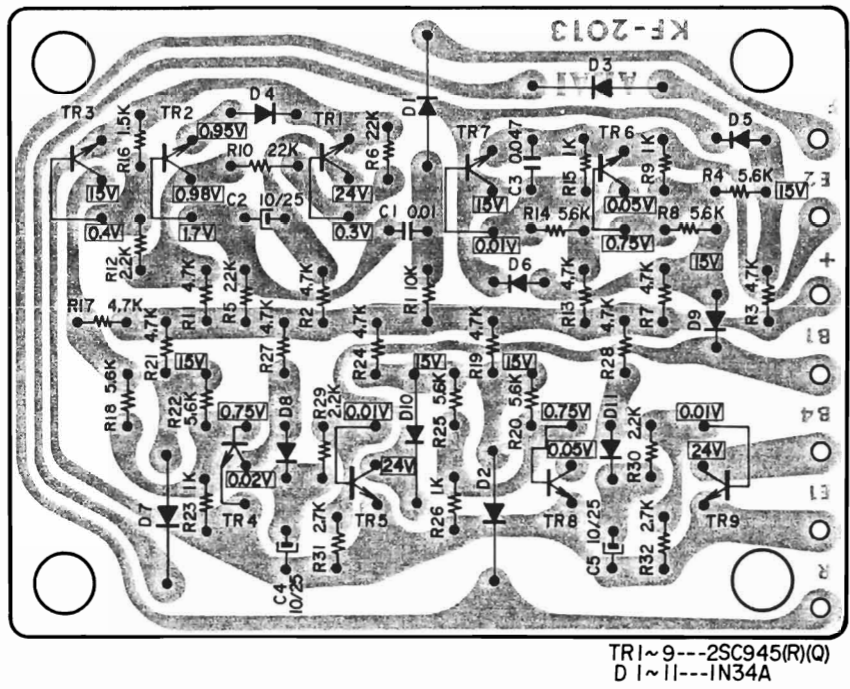

MODE SWITCH P.C. BOARD (KF-2012)

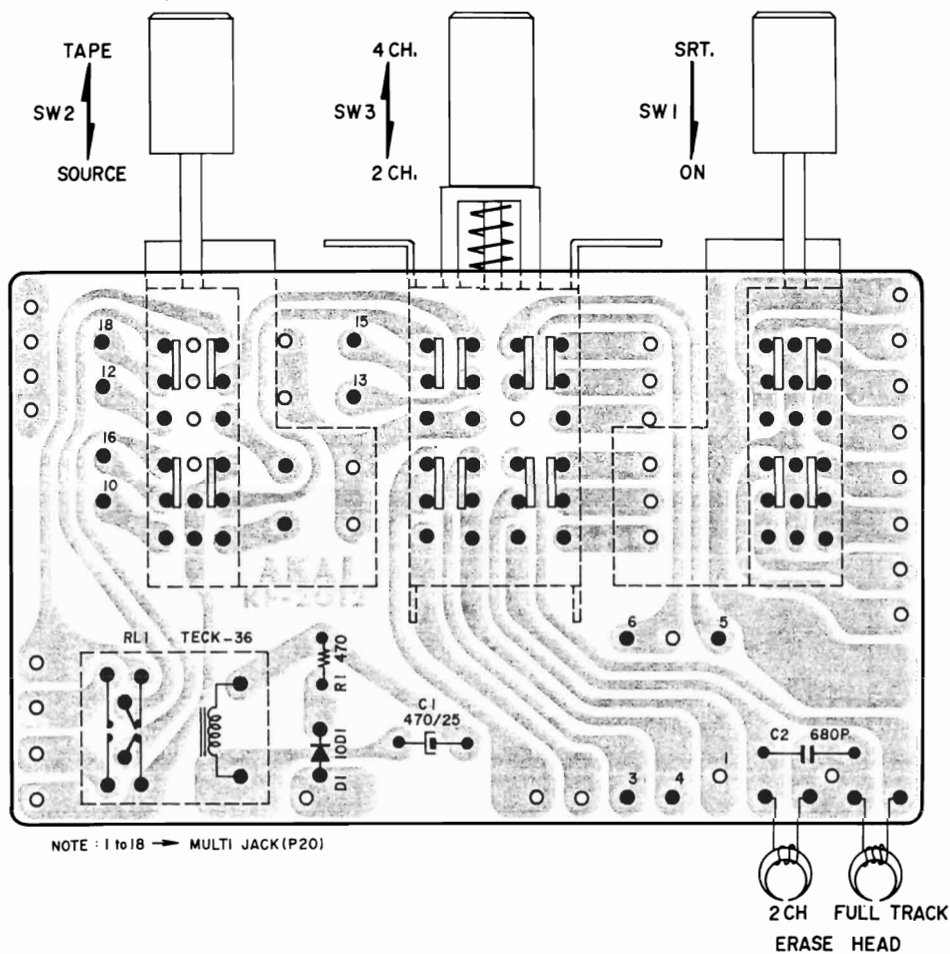

EQUALIZER SWITCH P.C. BOARD (KF-2014)

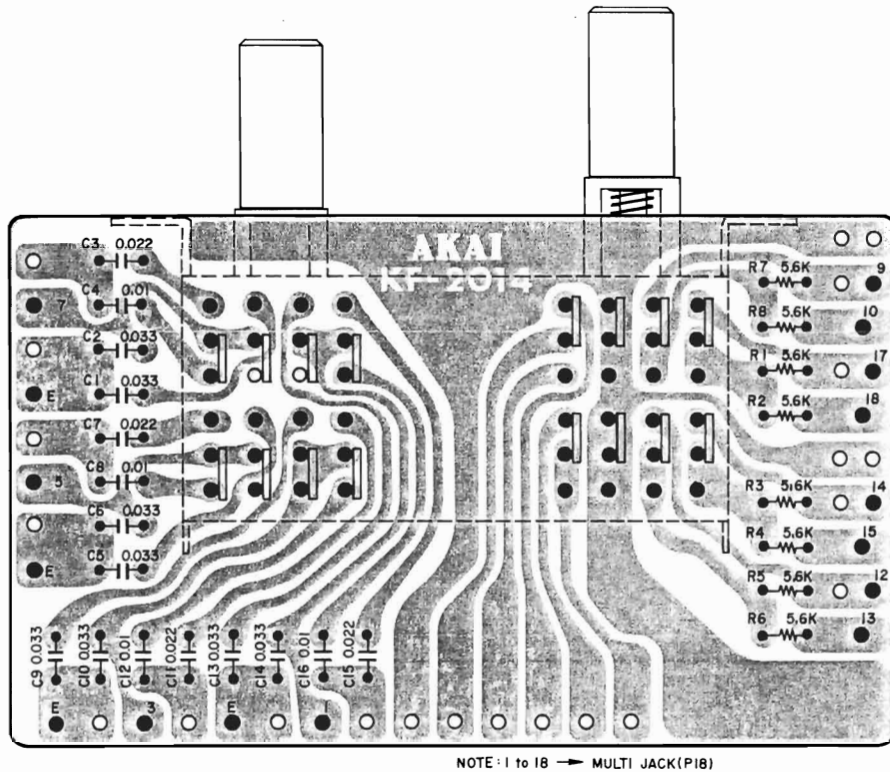

OPERATION LAMP P.C. BOARD (KF-1002)

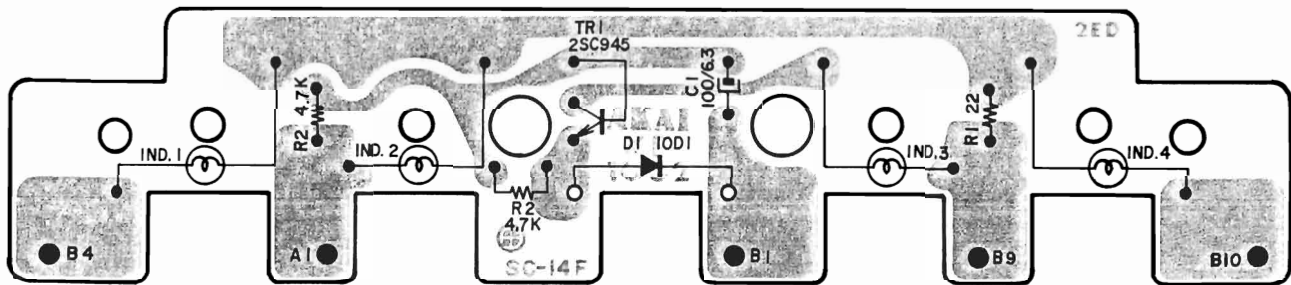

LINE JACK P.C. BOARD (KF-5014)

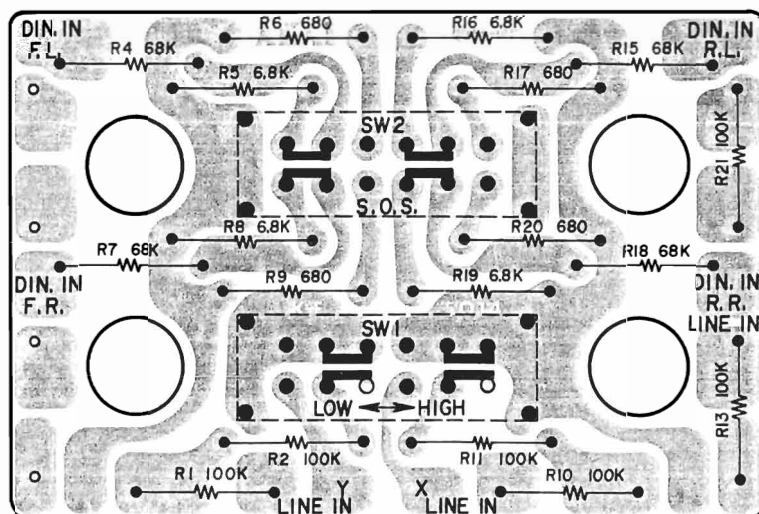

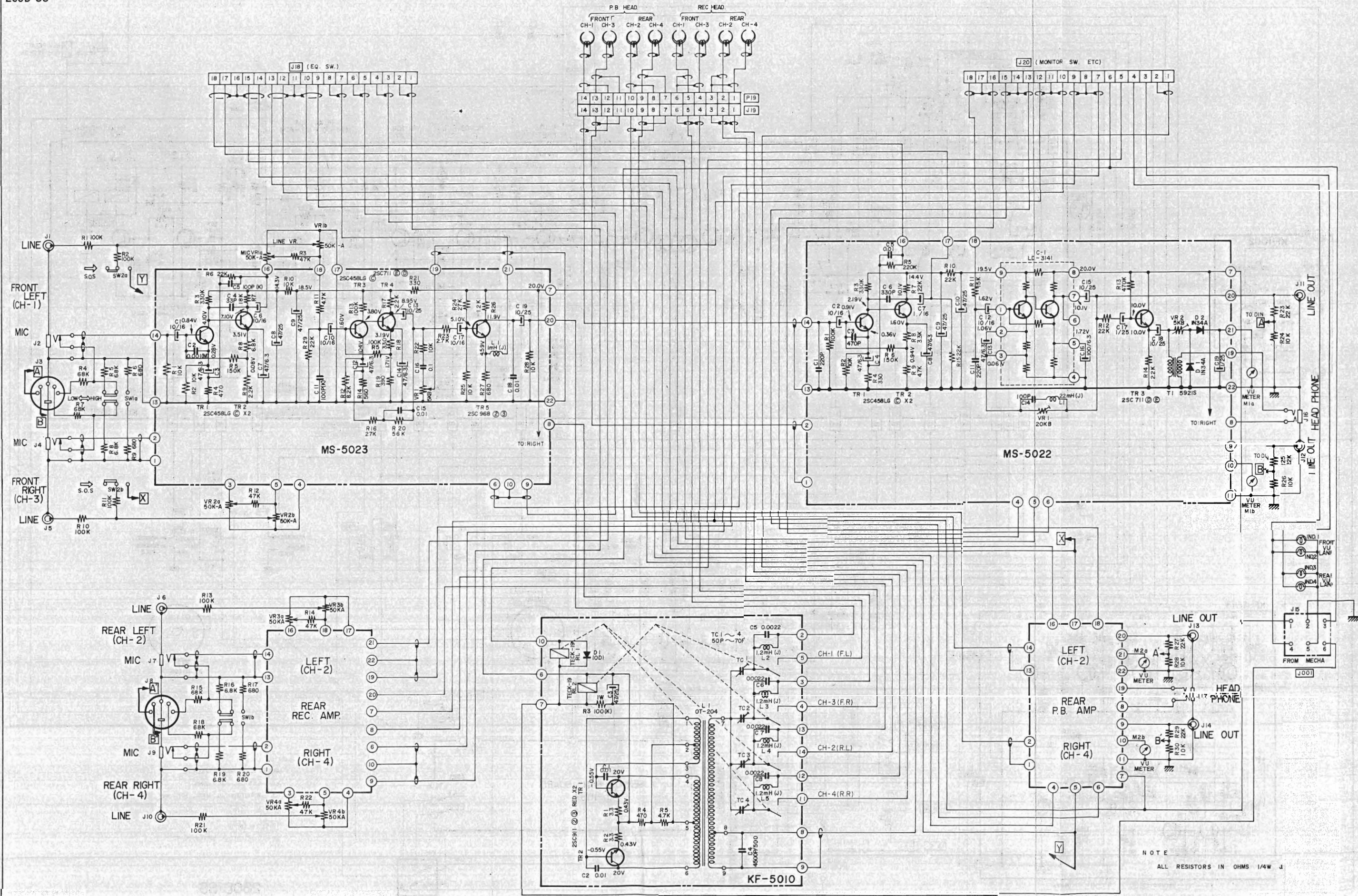

280D-SS
 AMPLIFIER SCHEMATIC DIAGRAM
 NO. 4-1 1421634A

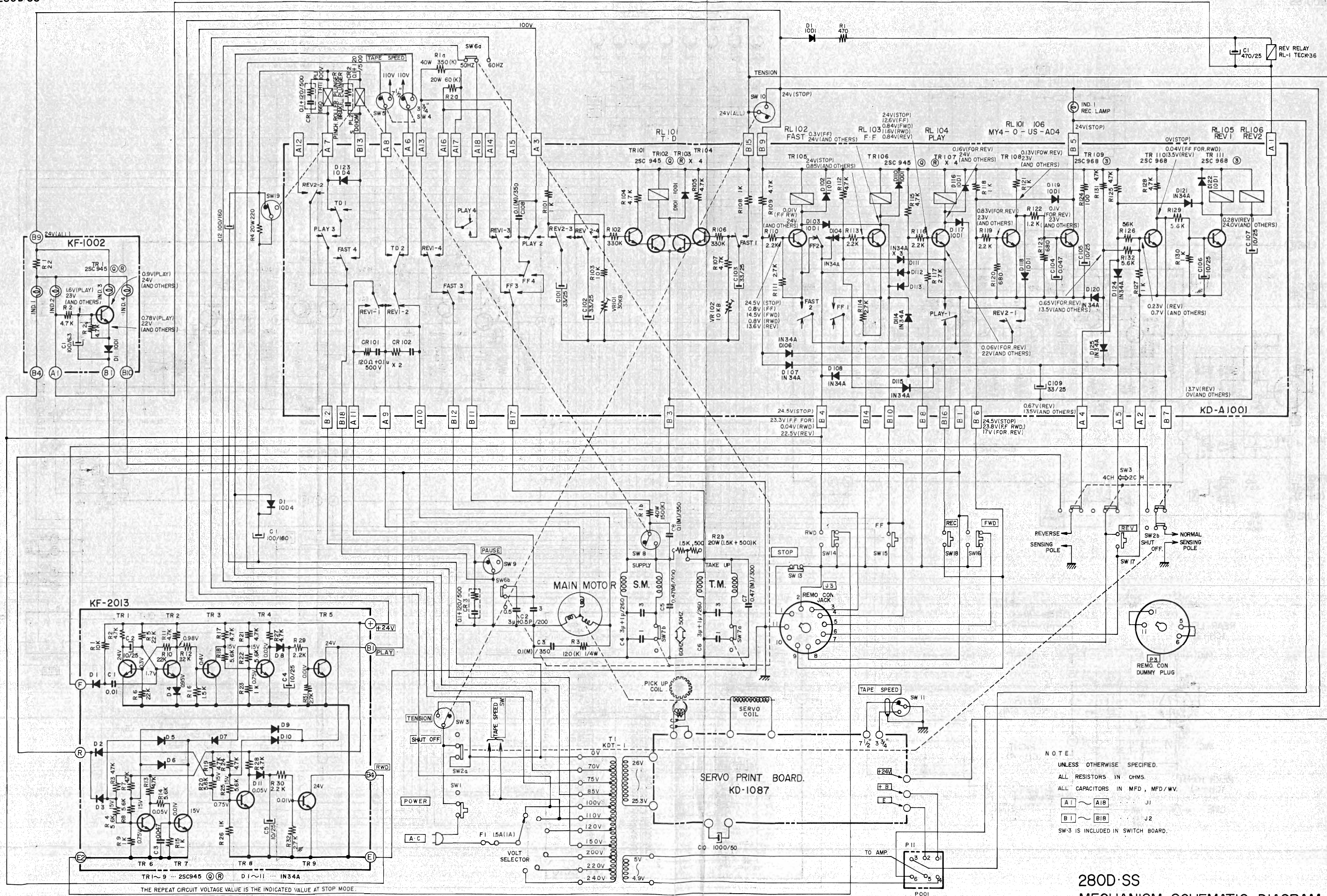

NOTE
 UNLESS OTHERWISE SPECIFIED.
 ALL RESISTORS IN OHMS.
 ALL CAPACITORS IN MFD, MFD/WV.
 A 1 ~ A 18 J1
 B 1 ~ B 18 J2
 SW-3 IS INCLUDED IN SWITCH BOARD.

280D-SS
 MECHANISM SCHEMATIC DIAGRAM
 NO.4-2 1421635A

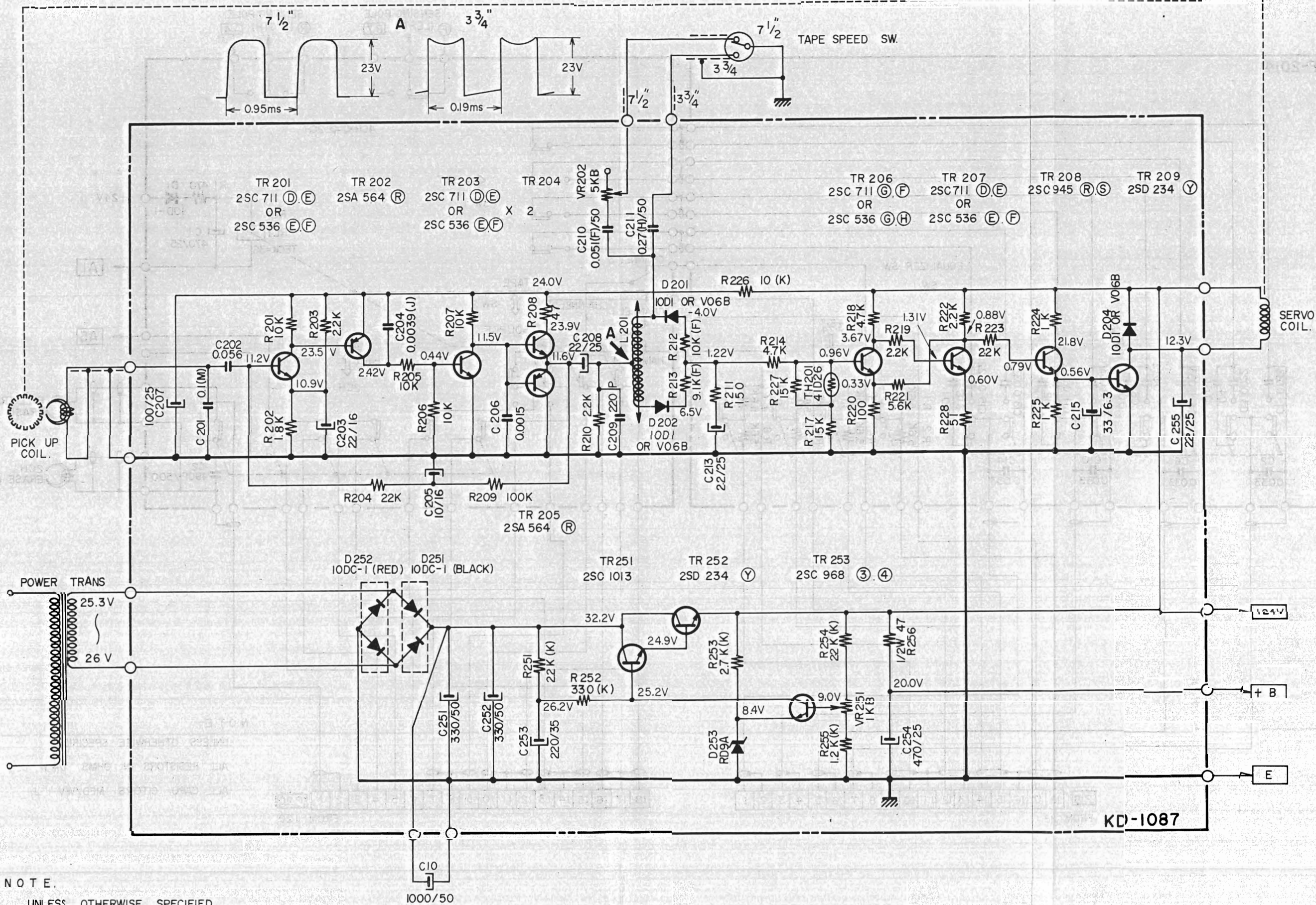

NOTE.
 UNLESS OTHERWISE SPECIFIED.
 ALL RESISTORS IN OHMS 1/4 W (J).
 ALL CAPACITORS IN MFD (K) 50WV, MFD/WV.

KF-2014

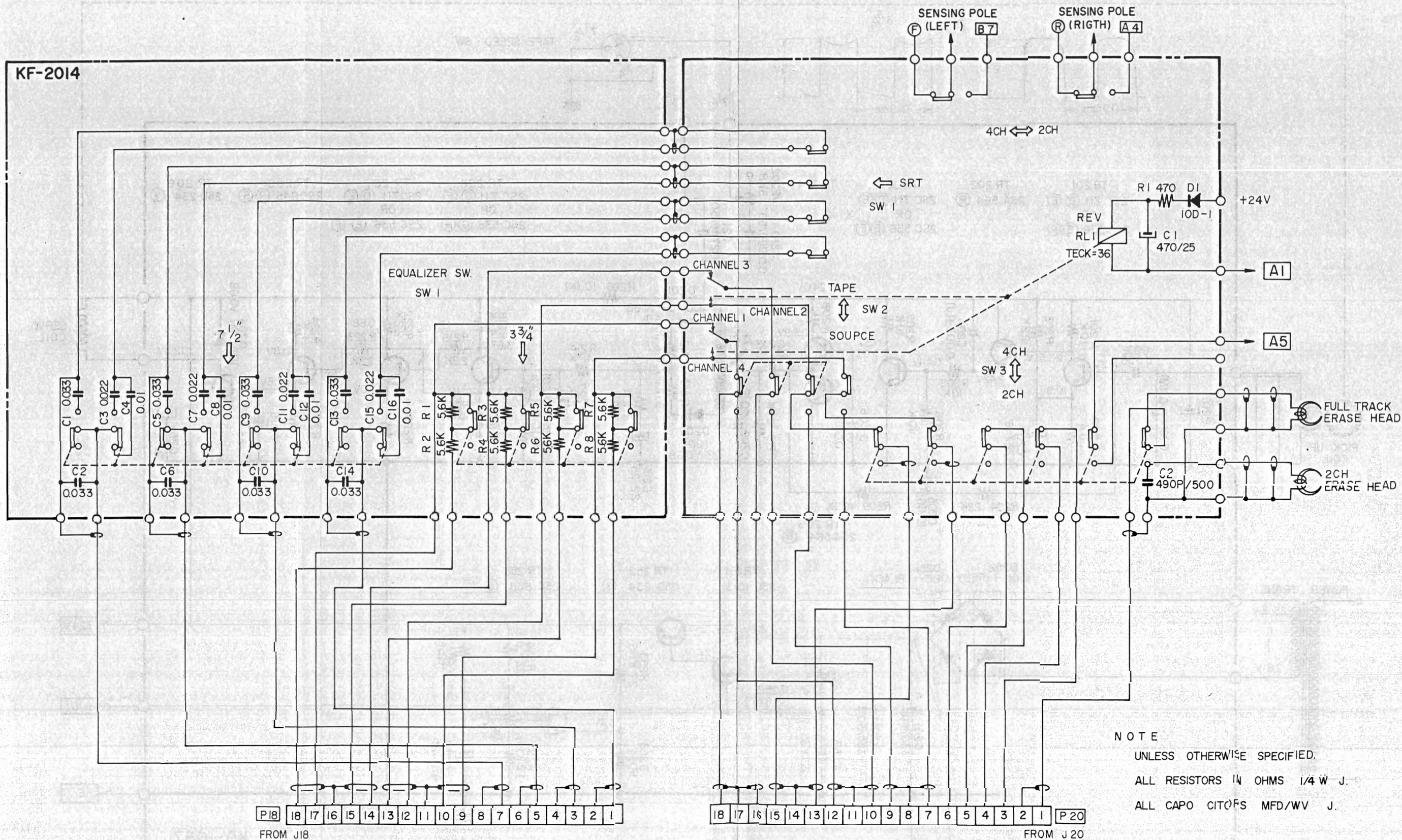

NOTE
 UNLESS OTHERWISE SPECIFIED.
 ALL RESISTORS IN OHMS 1/4 W J.
 ALL CAPS IN MFD/WV J.

280D-SS SWITCH BOARD SCHEMATIC DIAGRAM No.4-4 1421637A

SYSTEM CONTROL P.C. BOARD I. (KDA-1001B)

For easy repair, patterns of both sides of this P.C. Board are shown in the Service Manual.

By placing the transparent sheet on which (KD-A1001A) is shown over pattern (KD-A1001B) both sides can be seen at same time.

